

Membres de la commission de pré-validation:

--	--	--	--

Pré-validé Non validé

Observations :

Membres de la commission de validation:

--	--	--	--

Accepté Refusé

Observations :

IEN STI M.ROSIAU Denis	Date :	Signature :
---------------------------	--------	-------------

CAP RICS Session :2019-2020 Epreuve EP2

Option Chaudronnerie (Unité U2C) Option Soudage (Unité U2S)
 Configuration, réalisation et contrôle d'un ouvrage chaudronné / soudé
 Coefficient 12 +1 (PSE)

Etablissement de formation :
LP des 2 Caps Marquise

Intitulé du projet :
Cuve de sècherie

Origine du projet:
 Industrie
 Etablissement

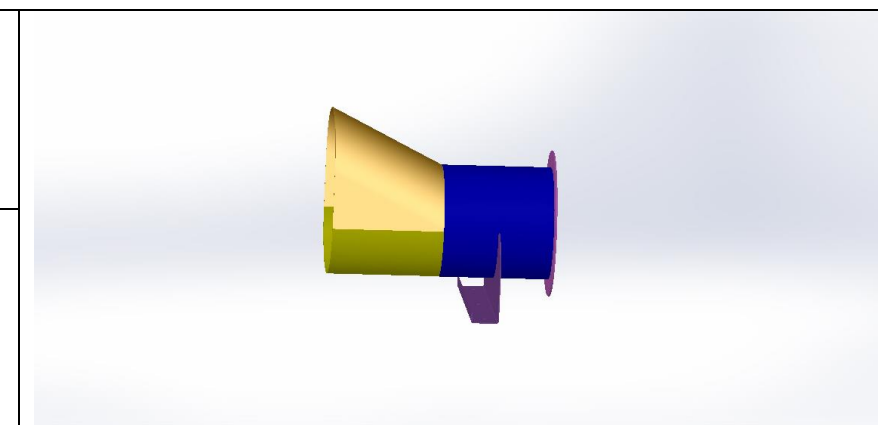

Nombre de candidats (mini 2) :
2 élèves TRCI

Enseignant (s) en responsabilité (s) du projet:

Soumrami Yoann.	<input checked="" type="checkbox"/> Réalisation <input type="checkbox"/> Construction	Aoumat Régis	<input checked="" type="checkbox"/> Réalisation <input type="checkbox"/> Construction	Dufour Luc	<input checked="" type="checkbox"/> Réalisation <input type="checkbox"/> Construction
-----------------	--	--------------	--	------------	--

Estimation du budget : **73€ TTC**

DDFPT de l'établissement : Mr Playe F	Date :	Signature :
Gestionnaire:	Date :	Signature :
Chef d'établissement: Mr Vaast M	Date :	Signature :

Documents à fournir à la commission de pré-validation :

- Descriptif technique du projet (Obligatoire)
- Plans d'ensemble et/ou définition (Obligatoire)
- Calendrier prévisionnel du projet (Obligatoire)
- Plan initial du projet
- Autres documents (Organisation,...)

A cocher

Documents ressources fournis aux candidats (facultatif aux commissions) :

- 3D numérique du projet
- Plan d'ensemble
- Plans de définition
- Extraits de normes
- Documents liés aux procédures de sécurité et au respect de l'environnement
- Descriptifs des moyens de contrôle et de réalisation
- Documents techniques numérisés (Dmos, Matières,...)

Moyens numériques utilisés :

- Logiciel CAO/DAO
 - Topsolid
 - Solidworks
 - Autre :.....
- Logiciel Logitrace
- Logiciel de programmation FAO
 - Alinéa
 - Topsolid
 - Profirst
 - Autre :.....
- Matériel informatique :
 - Poste informatique
 - Tablette
 - Autre :.....

A cocher

Compétences mobilisées non évaluées (Obligatoire):

C1 : Identifier décoder et interpréter les données de définition d'un ouvrage ou d'un élément

C2 : Préparer la fabrication de tout ou partie d'un ouvrage ou d'un élément

Compétences à évaluer (Obligatoire):

C3 : Configurer et régler les postes de travail

C4 : Réaliser un ou plusieurs éléments d'un ouvrage

C5 : Assembler les éléments de tout ou partie d'un ouvrage

C6 : Contrôler la réalisation

C7 : respecter les procédures relatives à la sécurité et au respect de l'environnement

Candidat 1 : Nom : Prénom :	<u>Réalisation de la cuve de sécherie</u>
Candidat 2 : Nom : Prénom :	<u>Réalisation de la cuve de sécherie</u>
Commun (Assemblage):	Les 2 candidats.

TRICS











	lundi 16/09	mardi 17/09	mercredi 18/09	jeudi 19/09	vendredi 20/09
8h00					
9h00		ENS.PROFESSIONNEL DUFOUR ATELIER ROC1,T11	ATELIER SOUMRANI ATELIER ROC2		ENS.PROFESSIONNEL AOUMAT ATELIER ROC1,T11
10h00	ENS.PROFESSIONNEL SOUMRANI ATELIER ROC2,T11				
11h00			ANGLAIS LV1 LATREMOLIERE P03	ED.PHYSIQUE & SPORT. OBERT	CONSTRUCTION LOYER T02
12h00			ED.PHYSIQUE & SPORT. OBERT		
13h00				CONSTRUCTION DUFOUR T01	HISTOIRE & GEOGRAPH. DHOQUOIS P14
14h00		ARTS APPLIQUES GUY P10			FRANCAIS DHOQUOIS P14
15h00	PRJT PLURIDISC.C.PRO SOUMRANI T09	FRANCAIS DHOQUOIS P14			ANGLAIS LV1 LATREMOLIERE P03
16h00		PREVENT.-SANTE-ENV. DUBOIS P11			Total:15h semaine
17h00					
18h00					

Calendrier 2019-2020

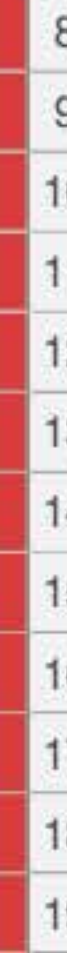
 Zone A

 Zone B

 Zone C

Janvier		Février		Mars		Avril		Mai		Juin	
1 M		1 S		1 D		1 M	P	1 V		1 L	
2 J		2 D		2 L		2 J	R	2 S		2 M	
3 V		3 L		3 M		3 V	O	3 D		3 M	
4 S		4 M		4 M		4 S		4 L		4 J	
5 D		5 M		5 J		5 D		5 M		5 V	
6 L		6 J		6 V		6 L		6 M		6 S	
7 M		7 V		7 S		7 M		7 J		7 D	
8 M		8 S		8 D		8 M		8 V		8 L	
9 J		9 D		9 L		9 J		9 S		9 M	
10 V		10 L		10 M		10 V		10 D		10 M	
11 S		11 M		11 M		11 S		11 L		11 J	
12 D		12 M		12 J		12 D		12 M		12 V	
13 L		13 J		13 V	P	13 L		13 M		13 S	
14 M		14 V		14 S	R	14 M		14 J		14 D	
15 M		15 S		15 D		15 M		15 V		15 L	
16 J		16 D		16 L		16 J		16 S		16 M	
17 V		17 L		17 M		17 V		17 D		17 M	
18 S		18 M		18 M		18 S		18 L		18 J	
19 D		19 M		19 J		19 D		19 M		19 V	
20 L		20 J		20 V	1TCI	20 L		20 M		20 S	
21 M		21 V		21 S	et	21 M		21 J		21 D	
22 M		22 S		22 D		22 M		22 V		22 L	
23 J		23 D		23 L	TRCI	23 J		23 S		23 M	
24 V		24 L		24 M		24 V		24 D		24 M	
25 S		25 M		25 M		25 S		25 L		25 J	
26 D		26 M		26 J		26 D		26 M		26 V	
27 L		27 J		27 V		27 L		27 M		27 S	
28 M		28 V		28 S		28 M		28 J		28 D	
29 M		29 S		29 D		29 M		29 V		29 L	
30 J				30 L		30 J		30 S		30 M	
31 V				31 M				31 D			

Grandes vacances le 4 juillet

via icalendrier.fr

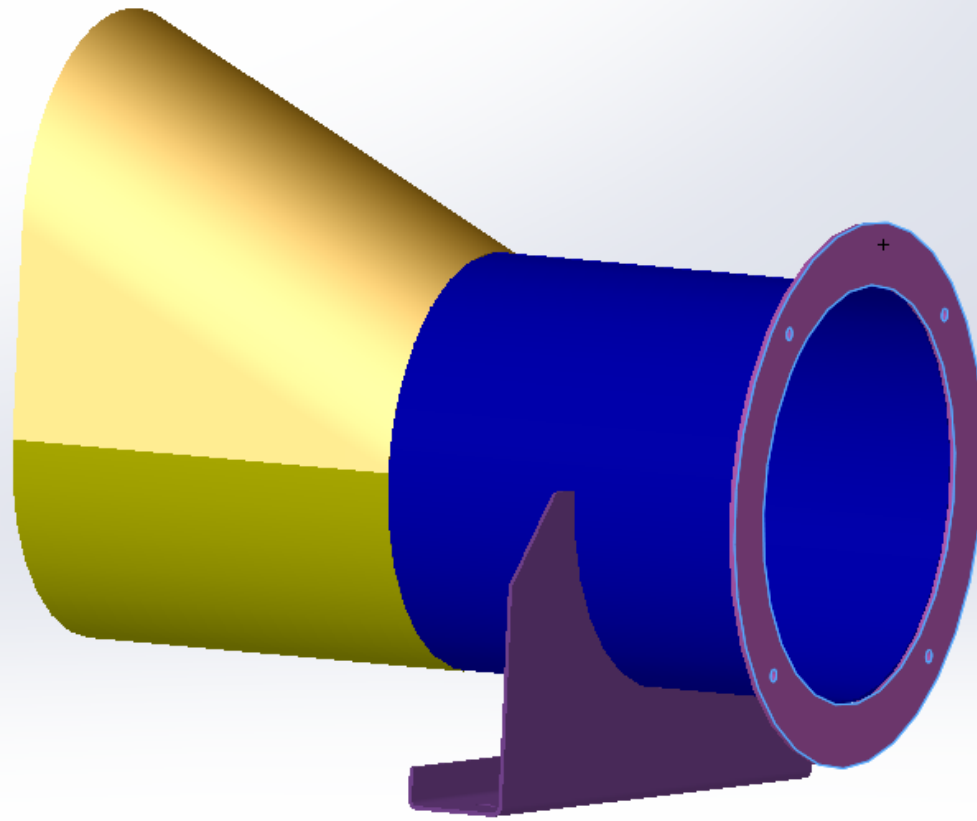

Projet N°2 Marquise Cuve de sècherie

Mise en situation générale

Unité de recyclage du papier imprimé et cartons :

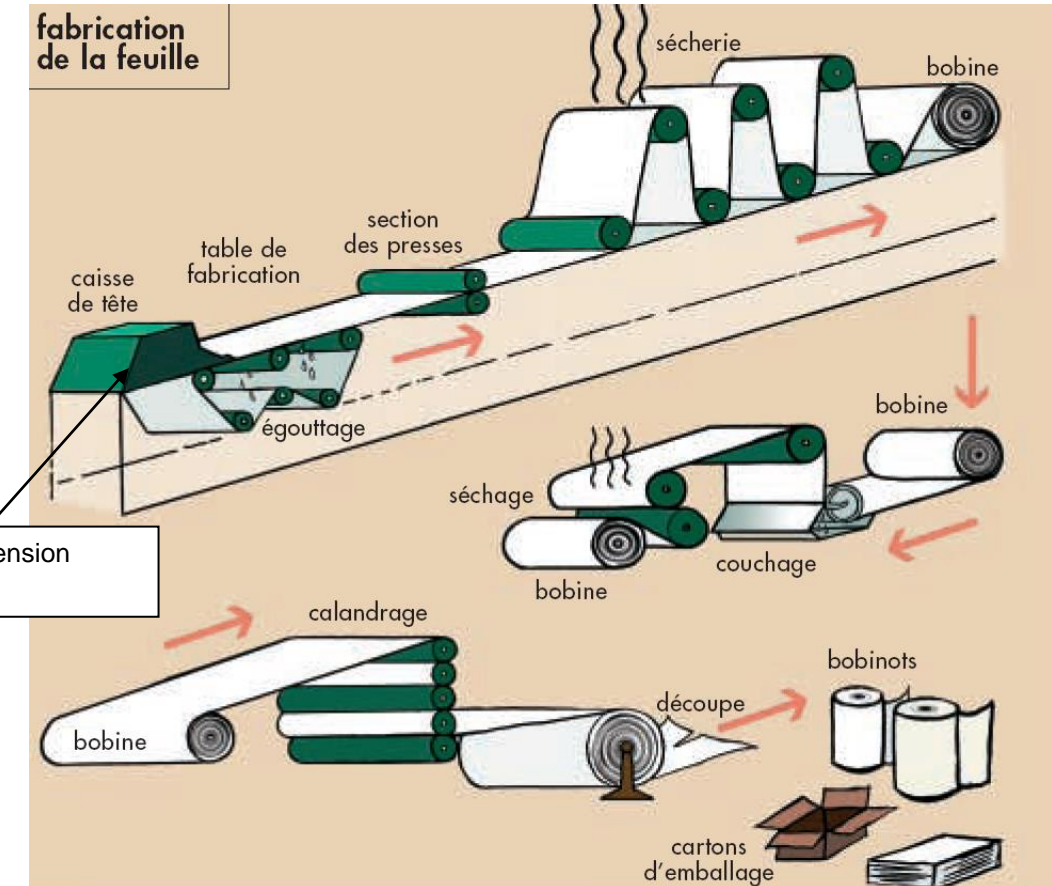
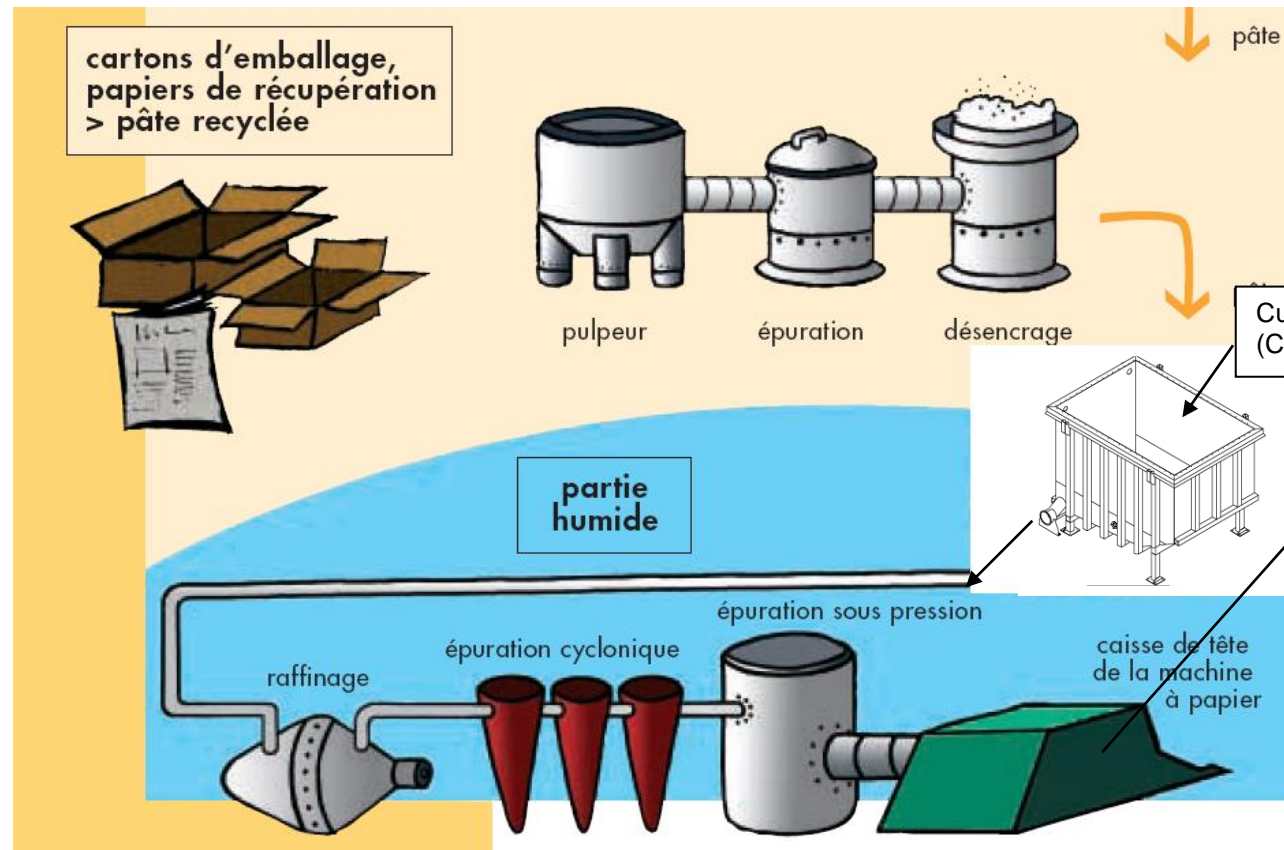

Pour recycler le papier imprimé il faut d'abord le transformer en pâte à papier et décrocher l'encre par malaxage.

Le pulpeur qui est un malaxeur exécute cette tâche.

L'épurateur permet de déposer les particules les plus lourdes (agrafes morceaux de plastic etc)

Le désencreur élimine les encres par action chimique.

La pâte à papier est ensuite stockée dans une cuve de mise en suspension.(objet de notre étude).

La pâte à papier continue son chemin de raffinage et d'épuration pour arriver dans la machine à papier.

Mise en situation

L'étude portera sur la fabrication de la sortie d'évacuation de la cuve qui sert à la mise en suspension de certaines impuretés : cette cuve s'appelle une « cuve de sècherie ».

Détail de la sortie d'évacuation de la cuve de sècherie

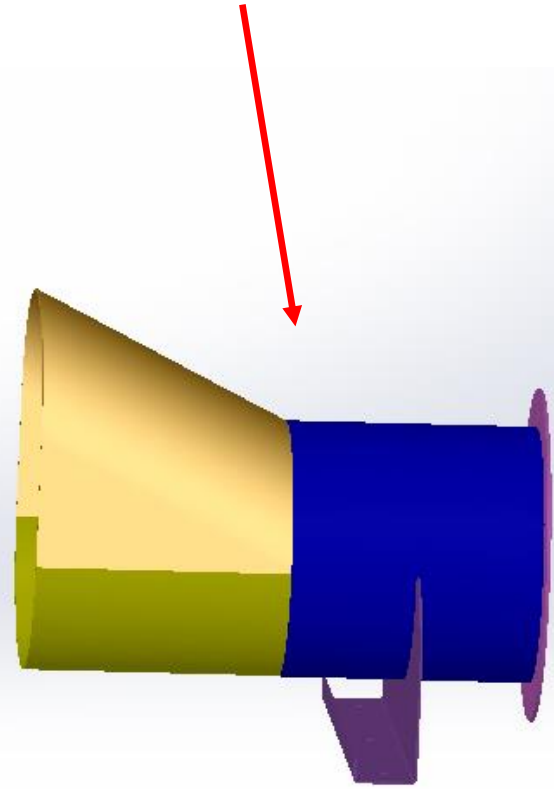

Problématique :

Après contrôle et étude, le bureau d'étude s'est aperçu que cuve de sècherie qu'il vous a donnée à fabriquer ne répondait pas au cahier des charges imposé par le code des appareils à pression (CODAP), il vous demande de modifier **la bride** en sortie de tuyauterie de la cuve de sècherie pour permettre un raccordement **sur une bride à collerette de la norme AFNOR PN10 DN 200**

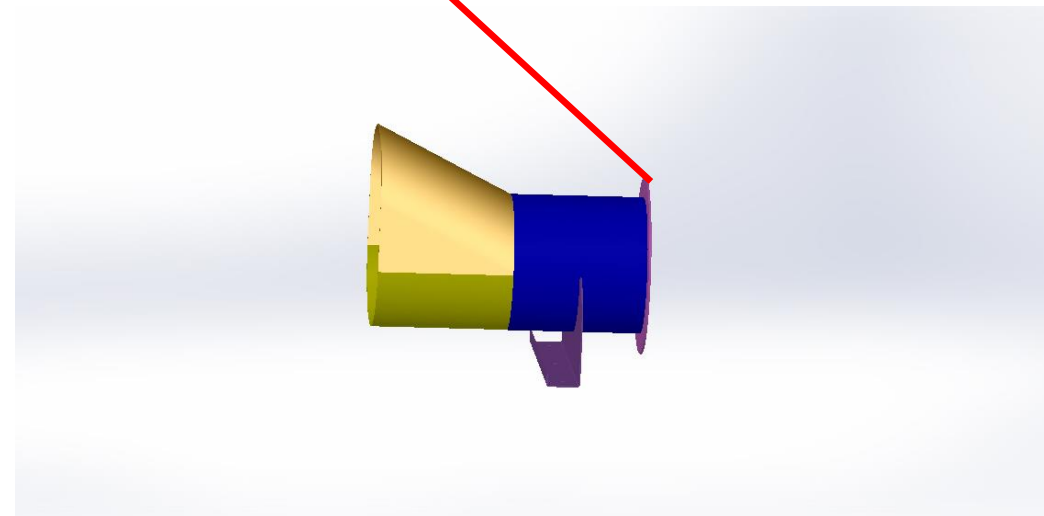

Pour se faire, représenter sur un nouveau dessin de définition les modifications à apporter sur la précédente bride et procéder par la même occasion à sa fabrication pour un éventuel remplacement futur.

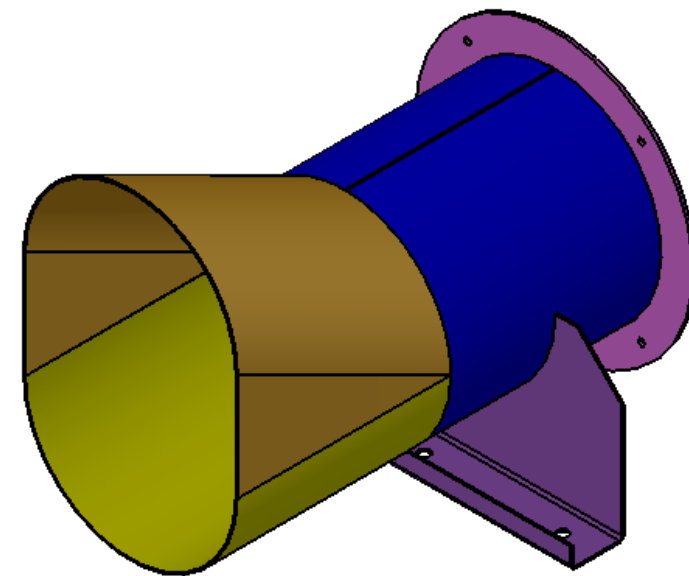
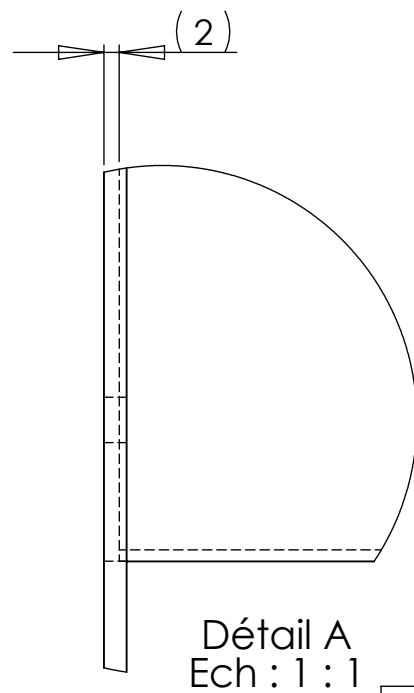
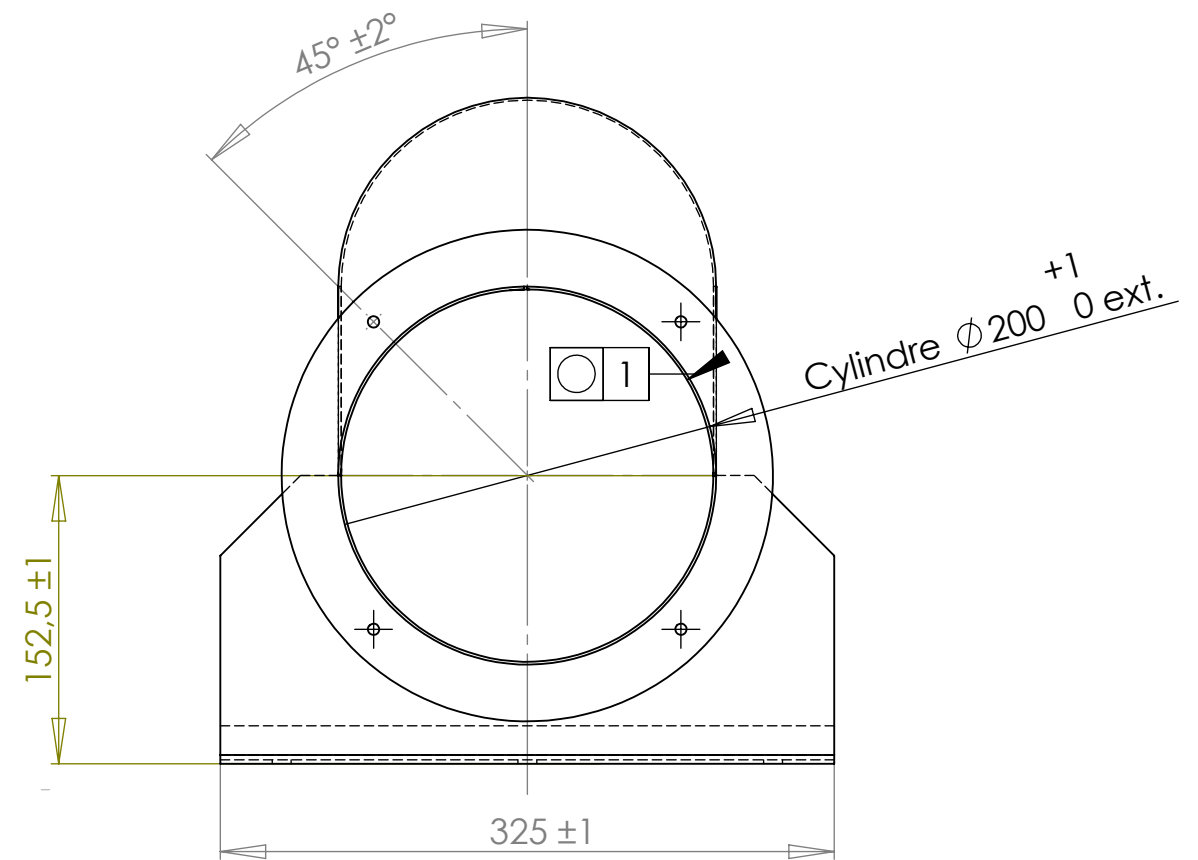
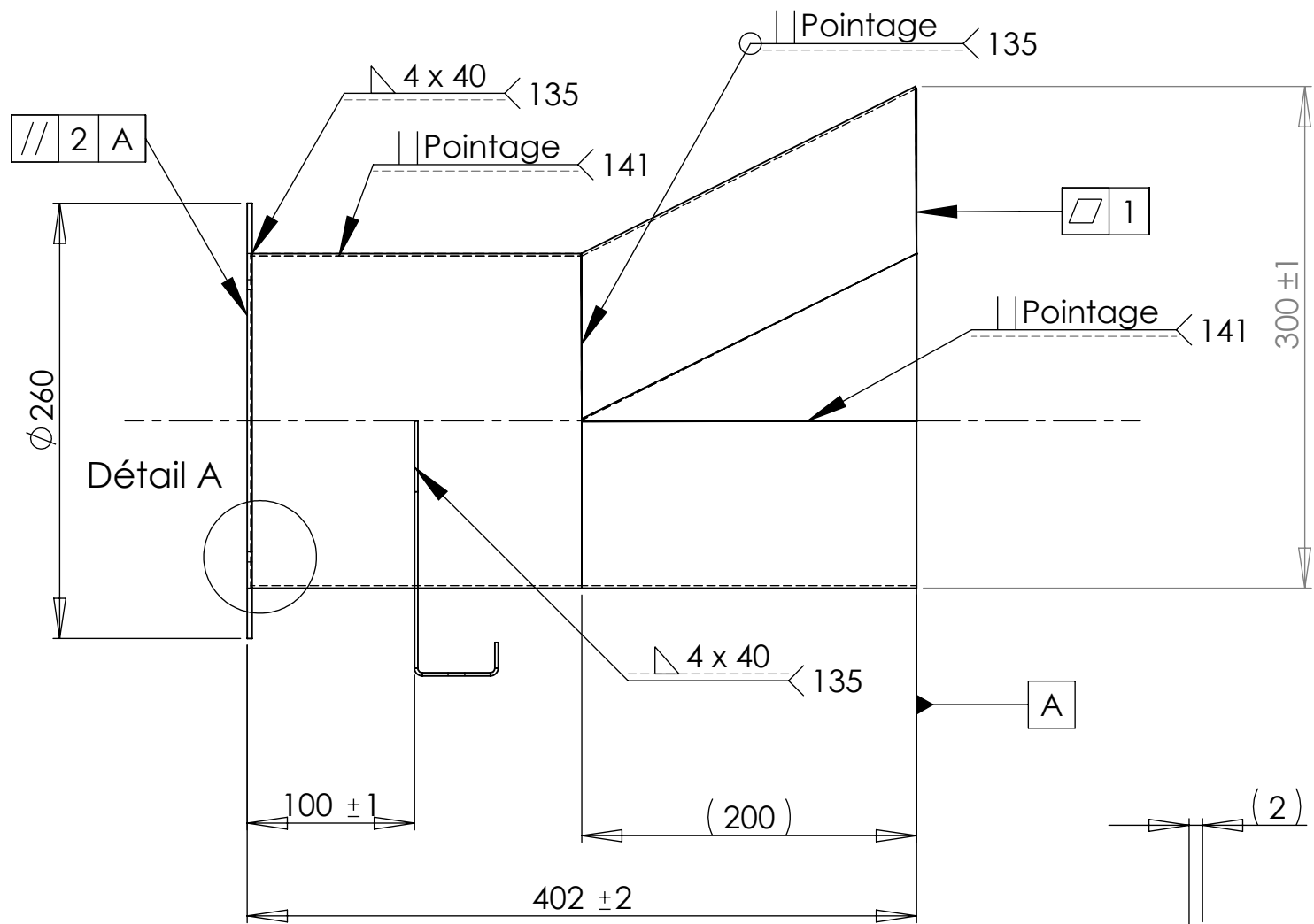

Rep	Nb	Désignation	Matière	Observations
Ech: 1 : 4		Dessiné par:	Plan de la sortie d'évacuation	
Le:				
			CUVE DE SECHERIE	
			Sortie évacuation	

1

2

3

4

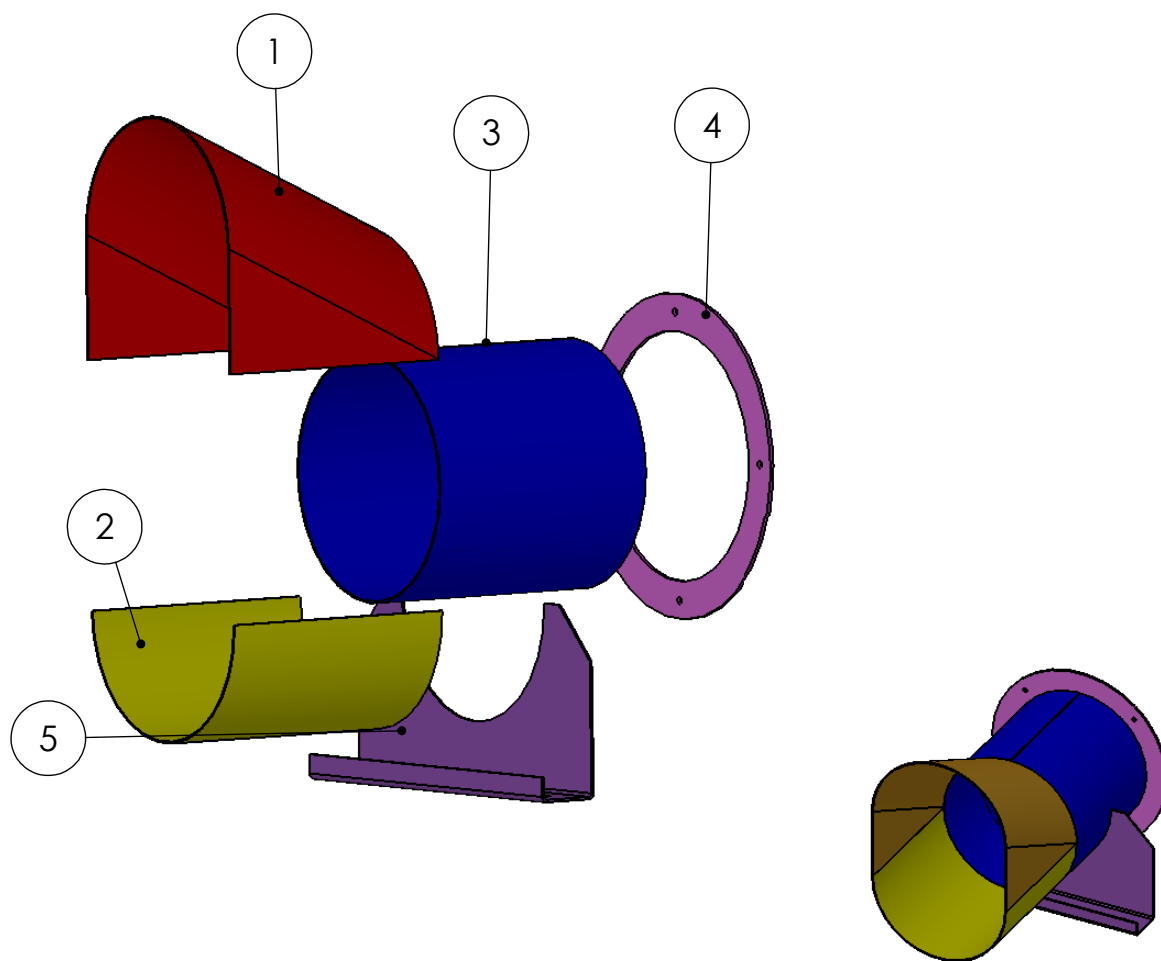

A

A

B

B

C

C

5	1	Berceau	S235 Ep 2 mm	
4	1	Bride	S235 Ep 3 mm	
3	1	Cylindre (LD= 623 mm.)	S235 Ep 1,5 mm.	
2	1	1/2 Cylindre	S235 Ep 1,5 mm.	
1	1	Surface composée	S235 Ep 1,5 mm.	
Rep	Nb	Désignation	Matière	Observations

D

D

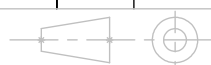

Format: A4 V

Ech.: :

Dessiné par:

Edition d'éducation de SOLIDWORKS – A titre éducatif uniquement.

Le //

1

2

3

4

1

2

3

4

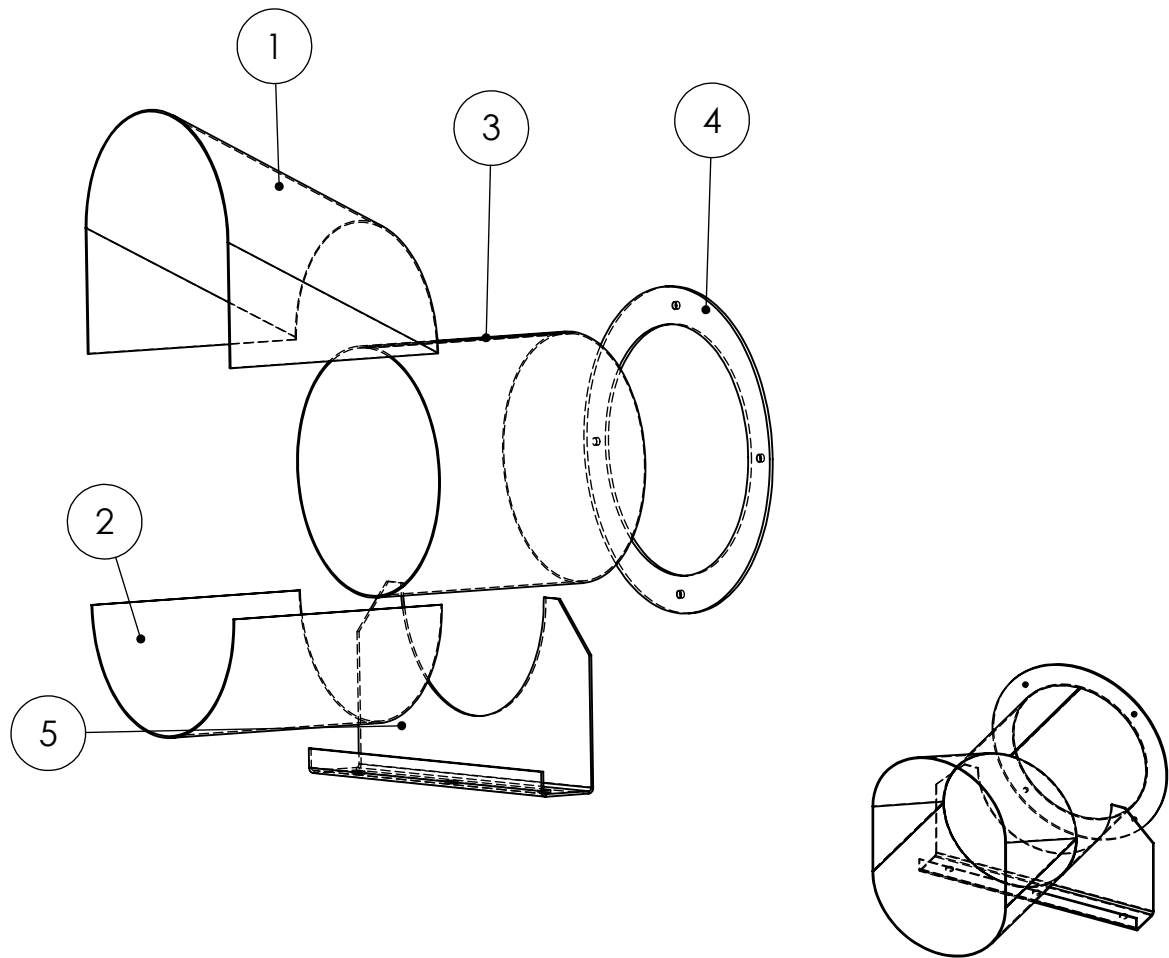

A

A

B

B

C

C

5	1	Berceau	S235 Ep 2mm	Débit : 325 x
4	1	Bride	S235 Ep 3mm	Découpe Aries 222
3	1	Cylindre	S235 Ep 1,5 mm.	Débit:
2	1	1/2 Cylindre	S235 Ep 1,5 mm.	
1	1	1/2 Surface composée	S235 Ep 1,5 mm.	Débit: 500 x 285
Rep	Nb	Désignation	Matière	Observations

D

D

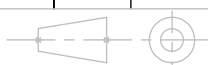

Format: A4 V

Ech.: :

Dessiné par:

CUVE DE SECHERIE

Sortie évacuation

Édition d'éducation de SOLIDWORKS – A titre éducatif uniquement.

DT 3/7

Le //

1

2

3

4

1

2

3

4

A

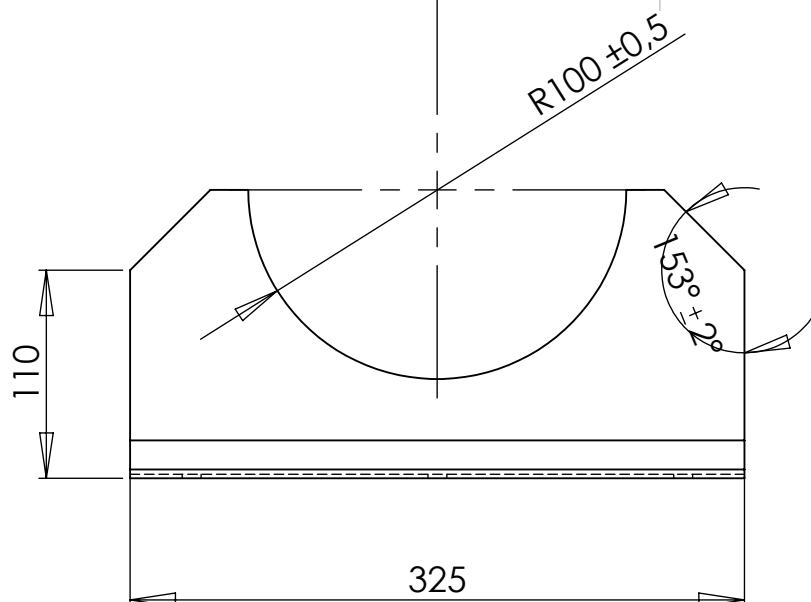

A

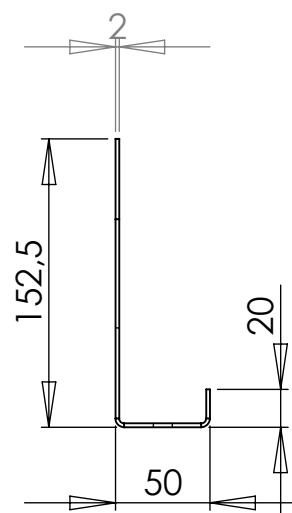

B

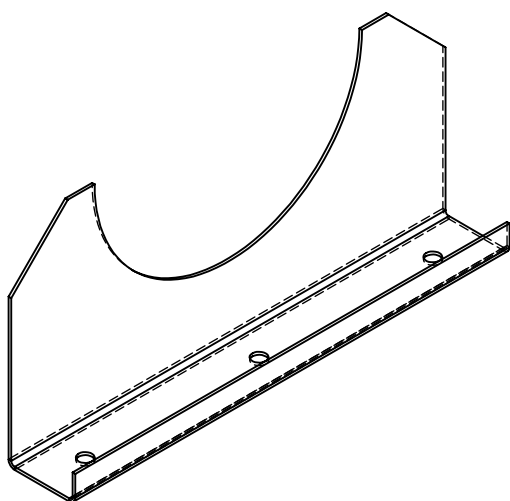

B

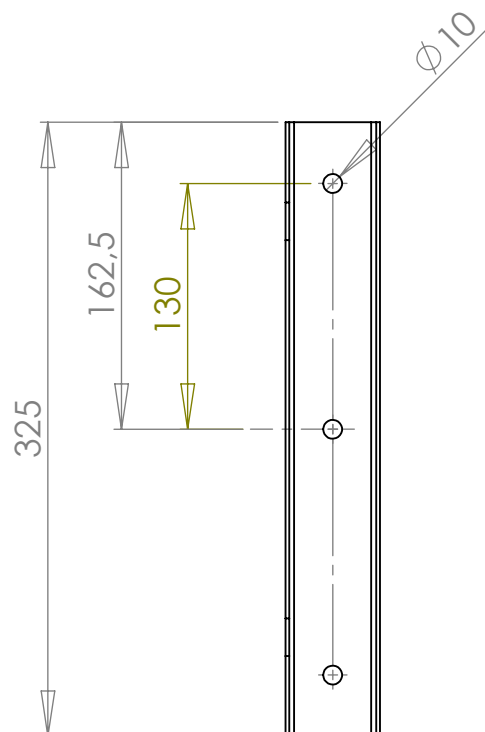

C

Tolérance générale ± 1

5	1	Berceau	S235 Ep2	Débit
Rep	Nb	Désignation	Matière	Observations
		<h1>CUVE DE SECHERIE</h1> <h2>Sortie évacuation</h2>		
Format: A4 V				
Ech.: 1 : 4				
Dessiné par:				
Le //				DT 5/7

1

2

3

4

D

D

1

2

3

4

A

A

B

B

C

C

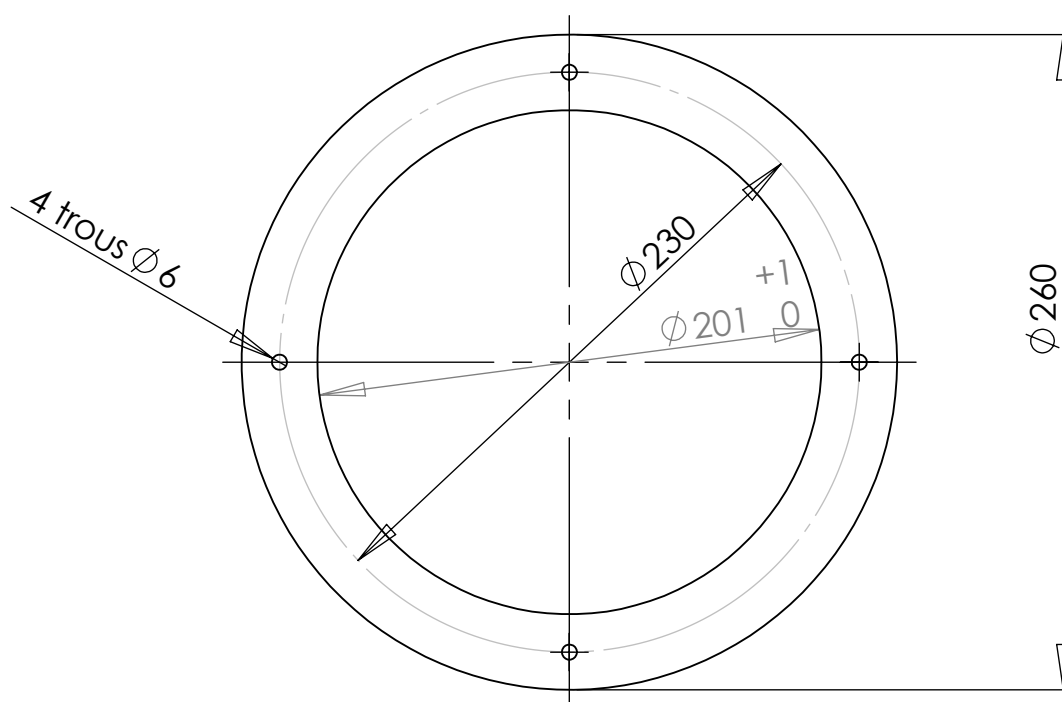

Tolérance générale $\pm 0,5$

4	1	Bride	S235 Ep3	Débit
Rep	Nb	Désignation	Matière	Observations
		<h1>CUVE DE SECHERIE</h1> <h2>Sortie évacuation</h2>		
Format: A4 V				
Ech.: : 1 : 3				
Dessiné par:				
Le //				

1

2

3

4

D

D

4

3

2

1

F

F

E

E

D

D

C

C

B

B

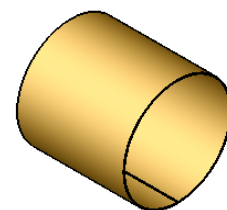
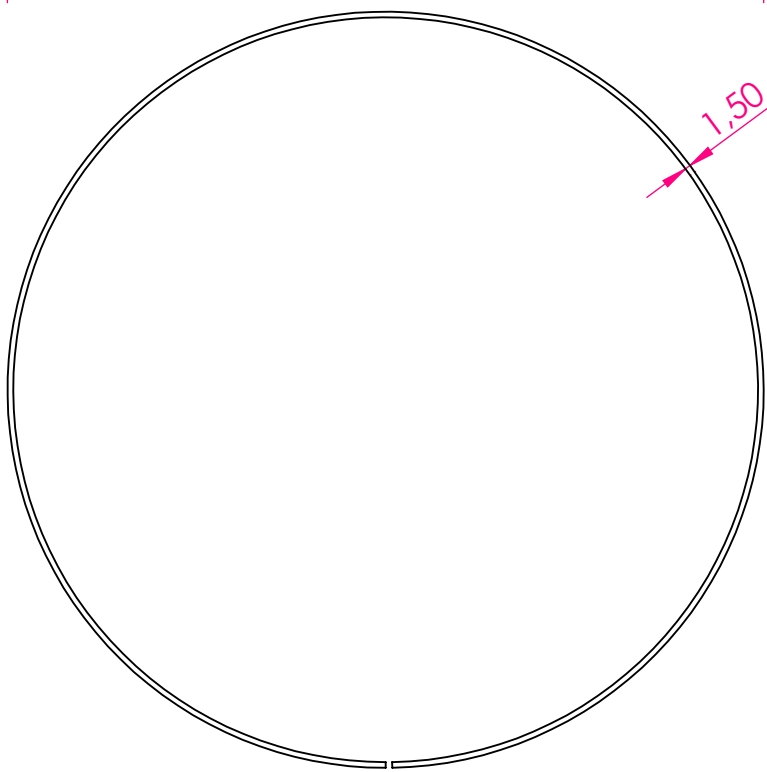
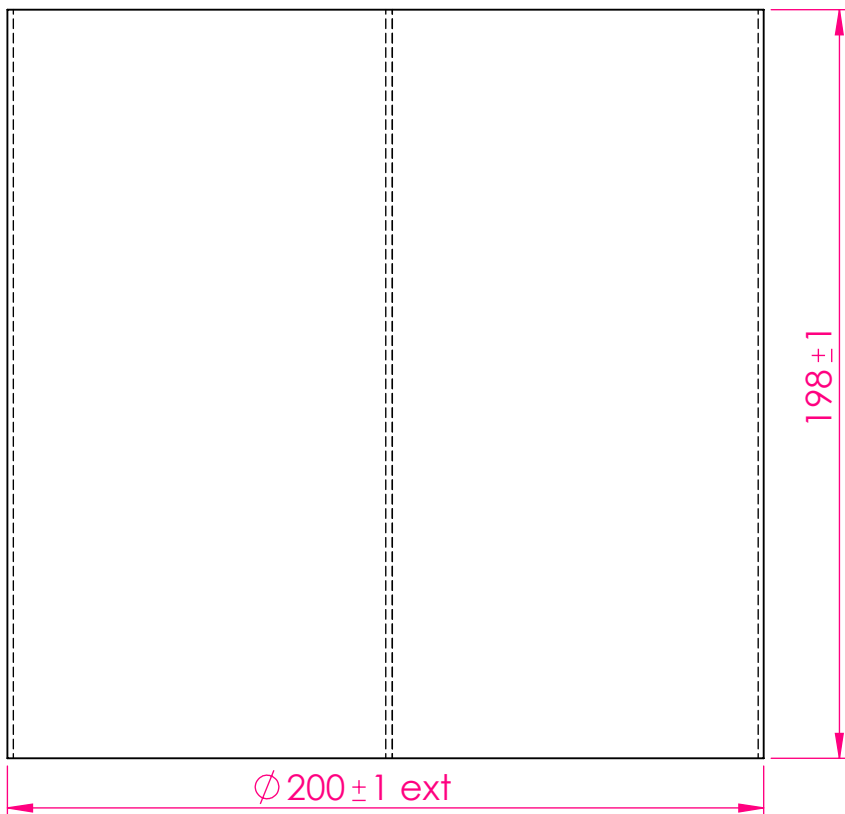

Echelle:

Lycée des 2 Caps Marquise

Nom:

1 / 2

Cylindre

Classe:

Date:



DL

4

3

2

1

A

A

4

3

2

1

F

F

E

E

D

D

C

C

B

B

200±1

1,50

R100

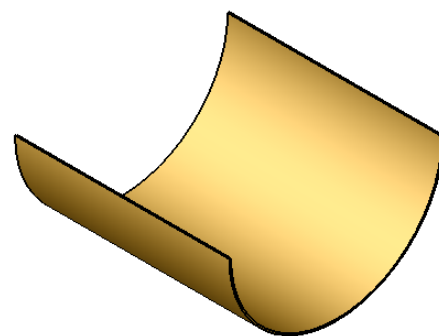

Echelle:

Lycée des 2 Caps Marquise

Nom:

1 / 2

1/2 Cylindre Cuve de sècherie

Classe:



DL

Date:

4

3

2

1

A

A

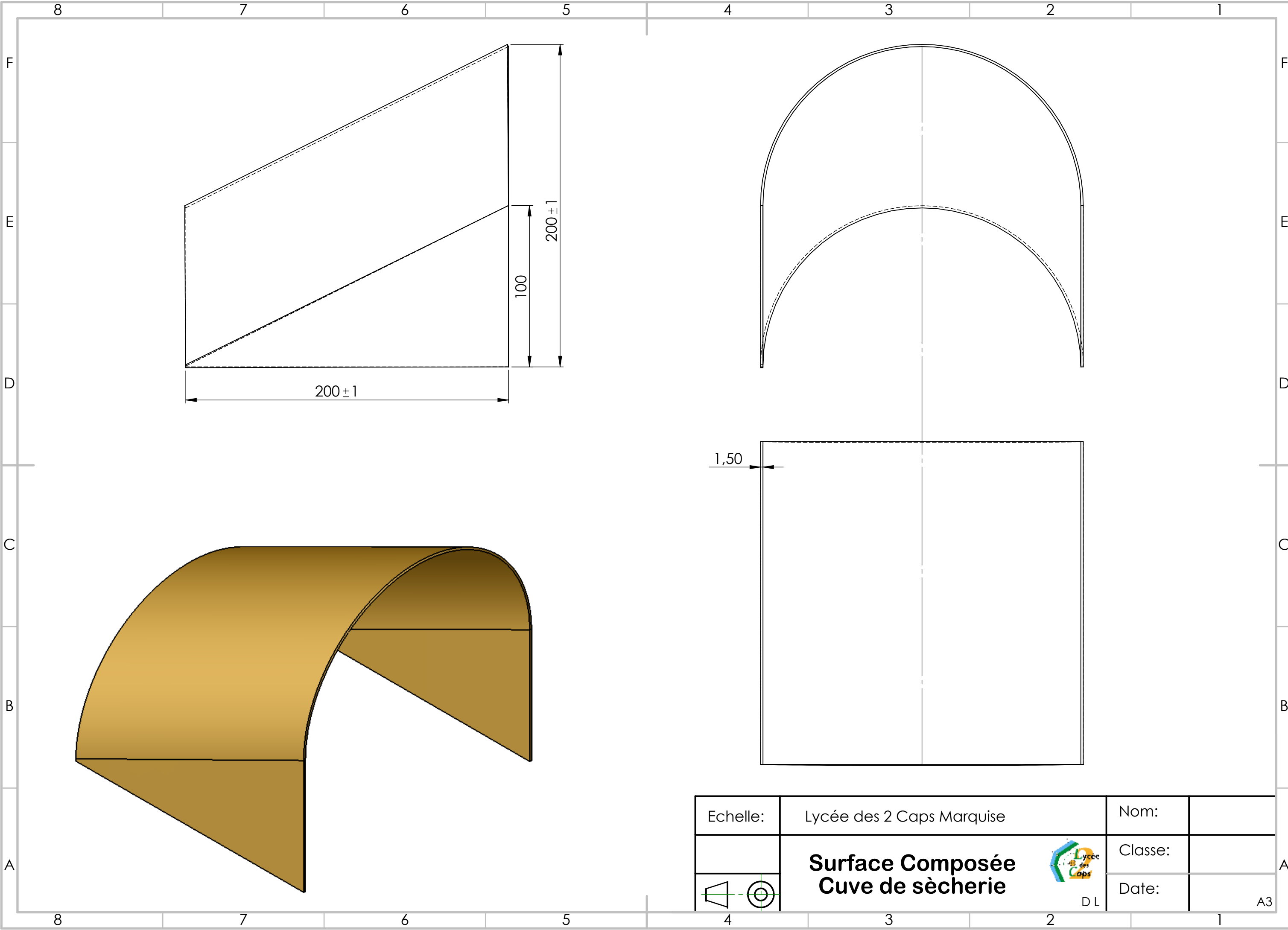

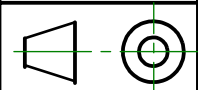

Echelle:	Lycée des 2 Caps Marquise	Nom:	
	Surface Composée Cuve de sècherie	Classe:	
		Date:	



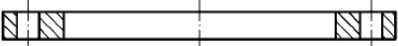
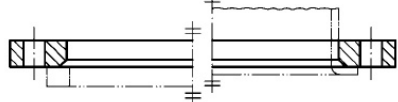

A3

DEFINITION DES TYPES DE BRIDES ET DE COLLETS - NF EN 1092-1
TYPES OF FLANGES AND COLLARS - NF EN 1092-1

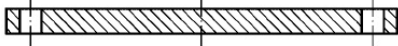

BRIDES SANS COLLERETTE - FLANGES WITHOUT WELDING NECK

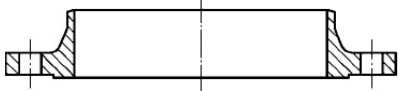
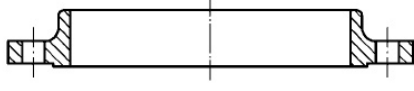
<p>TYPE 01</p> <p>Bride plate à souder <i>Welding flat flange</i></p> 	<p>TYPE 02</p> <p>Bride tournante sur collet à souder <i>Loose flat flange with welding neck</i></p> 
<p>TYPE 04</p> <p>Bride plate tournante sur collet à collerette à souder <i>Loose flat flange with welding neck collar</i></p> 	<p>TYPE 05</p> <p>Bride pleine <i>Blind flange</i></p> 

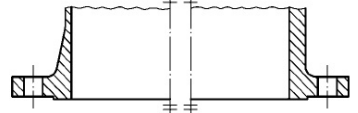

BRIDES AVEC COLLERETTE - WELDING NECK FLANGES

<p>TYPE 11</p> <p>Bride à collerette à souder bout à bout <i>Welding neck flange</i></p> 	<p>TYPE 12</p> <p>Bride à emmancher et à souder à collerette <i>Hubbed slip-on flange for welding</i></p> 
<p>TYPE 13</p> <p>Bride filetée à collerette <i>Neck threaded flange</i></p> 	<p>TYPE 21</p> <p>Bride incorporée <i>Integral flange long welding neck</i></p> 

COLLETS - WELDING NECKS

<p>TYPE 32</p> <p>Collet plat à souder <i>Welding flat collar</i></p> 	<p>TYPE 33</p> <p>Collet embouti à souder <i>Lapped pipe end</i></p> 
<p>TYPE 34</p> <p>Collet à collerette à souder <i>Welding neck collar</i></p> 	

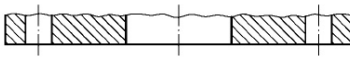
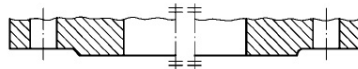
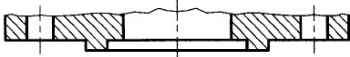
FACES DE JOINTS - FLANGE FACINGS

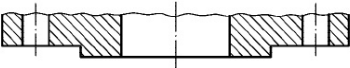
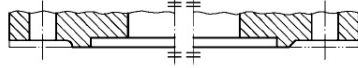
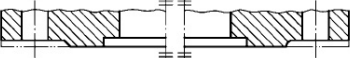
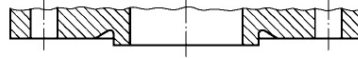
<p>TYPE A</p> <p>Face de joint plate <i>Flat face</i></p> 	<p>TYPE B</p> <p>Face de joint surélevée <i>Raised face</i></p> 
<p>TYPE C</p> <p>Emboîtement double mâle <i>Tongue face</i></p> 	<p>TYPE D</p> <p>Emboîtement double femelle <i>Groove face</i></p> 
<p>TYPE E</p> <p>Emboîtement mâle <i>Male face</i></p> 	<p>TYPE F</p> <p>Emboîtement femelle <i>Female face</i></p> 
<p>TYPE G</p> <p>Emboîtement femelle pour joint torique <i>Female face for O-ring</i></p> 	<p>TYPE H</p> <p>Emboîtement mâle pour joint torique <i>Male face for O-ring</i></p> 

DIMENSIONS DES PORTEES DE JOINT - NF EN 1092-1

FLANGE FACING DIMENSIONS - NF EN 1092-1

TYPE A	TYPE B	TYPE C	TYPE D
			
Face de joint plate <i>Flat face</i>	Face de joint surélevée <i>Raised face</i>	Emboîtement double mâle <i>Tongue face</i>	Emboîtement double femelle <i>Groove face</i>
TYPE E	TYPE F	TYPE G	TYPE H
			
Emboîtement mâle <i>Male face</i>	Emboîtement femelle <i>Female face</i>	Emboîtement F. pour joint torique <i>Female face for O-ring</i>	Emboîtement M. pour joint torique <i>Male face for O-ring</i>

TABLEAU DES DIMENSIONS - DIMENSIONS

DN	d ₁ (mm)						f ₁ (mm)	f ₂ (mm)	f ₃ (mm)	f ₄ (mm)	W (mm)	X (mm)	Y (mm)	Z (mm)	α	R (mm)
	PN 6	PN 10	PN 16	PN 25	PN 40	PN 63										
10	35			40			2	4.5	4.0	2.0	24	34	35	23	-	2.5
15	40			45			2	4.5	4.0	2.0	29	39	40	28	-	2.5
20	50			58			2	4.5	4.0	2.0	36	50	51	35	41°	2.5
25	60			68			2	4.5	4.0	2.0	43	57	58	42	41°	2.5
32	70			78			2	4.5	4.0	2.0	51	65	66	50	41°	2.5
40	80			88			2	4.5	4.0	2.0	61	75	76	60	41°	2.5
50	90			102			2	4.5	4.0	2.0	73	87	88	72	41°	2.5
65	110			122			2	4.5	4.0	2.0	95	109	110	94	41°	2.5
80	128			138			2	4.5	4.0	2.0	106	120	121	105	41°	2.5
100	148	158	158	162	162	162	2	5.0	4.5	2.5	129	149	150	128	32°	3
125	178	188	188	188	188	188	2	5.0	4.5	2.5	155	175	176	154	32°	3
150	202	212	212	218	218	218	2	5.0	4.5	2.5	183	203	204	182	32°	3
200	258	268	268	278	285	285	2	5.0	4.5	2.5	239	259	260	238	32°	3
250	312	320	320	335	345	345	2	5.0	4.5	2.5	292	312	313	291	32°	3
300	365	370	378	395	410	410	2	5.0	4.5	2.5	343	363	364	342	32°	3
350	415	430	438	450	465	465	2	5.5	5.0	3.0	395	421	422	394	27°	3.5
400	465	482	490	505	535	535	2	5.5	5.0	3.0	447	473	474	446	27°	3.5
450	520	532	550	555	560	560	2	5.5	5.0	3.0	497	523	524	496	27°	3.5
500	570	585	610	615	615	615	2	5.5	5.0	3.0	549	575	576	548	27°	3.5
600	670	685	725	720	735	735	2	5.5	5.0	3.0	649	675	676	648	27°	3.5
700	775	800	795	820	-	840	2	5.5	5.0	3.0	751	777	778	750	27°	3.5
800	880	905	900	930	-	960	2	5.5	5.0	3.0	856	882	883	855	27°	3.5
900	980	1005	1000	1030	-	1070	2	5.5	5.0	3.0	961	987	988	960	27°	3.5
1000	1080	1110	1115	1140	-	1180	2	6.5	6.0	4.0	1062	1092	1094	1060	27°	3.5

BRIDES A COLLERETTE A SOUDER EN BOUT - ACIER OU INOX - TYPE 11 B
WELDING NECK FLANGES - C. OR S. STEEL - TYPE 11 B

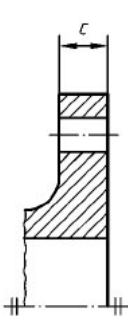
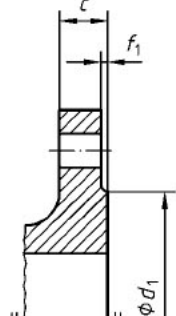
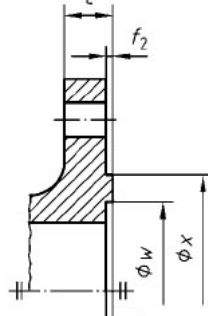
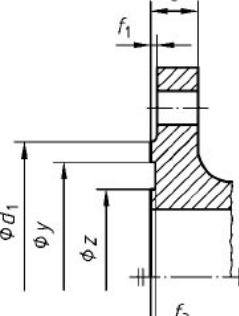
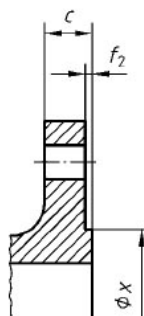
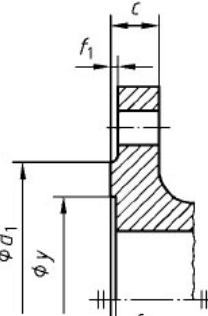
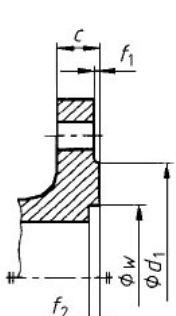
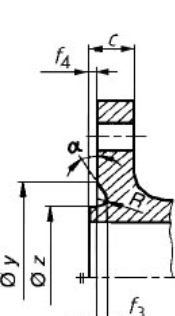

Construction suivant EN 1092-1

Execution according to EN 1092-1

Acier carbone
 Acier allié
 Inox 316 L, 304 L
 Super alliages

Carbon steel
 Alloy steel
 AISI 316 L, 304L
 Exotic alloys

BRIDE ACIER A COLLERETTE PN 6 - WN FLANGE, PN 6

10006

DN	Collerette			Ø ext. D	Epais. C ₂	Hauteurs		Perçage		Portée de joint		Poids (kg)
	Ø A ₁	Ep. S	Ø N ₁			H ₂	H ₃	n x L	Ø K	Ø d ₁	f ₁	
10	17.2	1.8	26	75	12	28	6	4 x 11	50	35	2	0.5
15	21.3	2.0	30	80	12	30	6	4 x 11	55	40	2	0.5
20	26.9	2.3	38	90	14	32	6	4 x 11	65	50	2	0.5
25	33.7	2.6	42	100	14	35	6	4 x 11	75	60	2	1.0
32	42.4	2.6	55	120	14	35	6	4 x 14	90	70	2	1.0
40	48.3	2.6	62	130	14	38	7	4 x 14	100	80	2	1.5
50	60.3	2.9	74	140	14	38	8	4 x 14	110	90	2	1.5
65	76.1	2.9	88	160	14	38	9	4 x 14	130	110	2	2.0
80	88.9	3.2	102	190	16	42	10	4 x 18	150	128	2	3.0
100	114.3	3.6	130	210	16	45	10	4 x 18	170	148	2	3.5
125	139.7	4.0	155	240	18	48	10	8 x 18	200	178	2	4.5
150	168.3	4.5	184	265	18	48	12	8 x 18	225	202	2	5.5

Construction suivant EN 1092-1 (≈ DIN 2631)
 Acier carbone

Variantes : inox 304 L, 316 L, ...
 Option : cote S à la demande

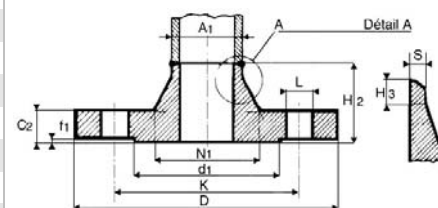

BRIDE ACIER A COLLERETTE PN 10 - WN FLANGE, PN 10

10010

DN	Collerette			Ø ext. D	Epais. C ₂	Hauteurs		Perçage		Portée de joint		Poids (kg)
	Ø A ₁	Ep. S	Ø N ₁			H ₂	H ₃	n x L	Ø K	Ø d ₁	f ₁	
10 au 40	Utiliser les dimensions PN 40 - Use dimensions of PN 40											
50 au 150	Utiliser les dimensions PN 16 - Use dimensions of PN 16											
200	219.1	6.3	234	340	24	62	16	8 x 22	295	268	2	11.5
250	273.0	6.3	292	395	26	68	16	12 x 22	350	320	2	15.5
300	323.9	7.1	342	445	26	68	16	12 x 22	400	370	2	18.0
350	355.6	7.1	385	505	26	68	16	16 x 22	460	430	2	24.5
400	406.4	7.1	440	565	26	72	16	16 x 26	515	482	2	29.5
450	457	7.1	488	615	28	72	16	20 x 26	565	532	2	34.0
500	508	7.1	542	670	28	75	16	20 x 26	620	585	2	39.5
600	610	7.1	642	780	28	80	18	20 x 30	725	685	2	56.0
700	711	8	746	895	30	80	18	24 x 30	840	800	2	65.0
800	813	8	850	1015	32	90	18	24 x 33	950	905	2	87.0
900	914	10	950	1115	34	95	20	28 x 33	1050	1005	2	106.0
1000	1016	10	1052	1230	34	95	20	28 x 36	1160	1110	2	123.0

Construction suivant EN 1092-1 (≈ DIN 2632)

- acier carbone : réf. **10010**
- inox 316 L : réf. **10010 I**

Variantes : inox 304 L, ...
 Sur demande :
 - DN 1200 au DN 3000
 - cote S pour sch. 40 ; 80 ; 160

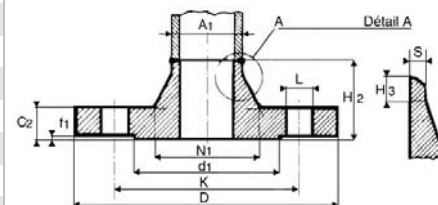

BRIDE ACIER A COLLERETTE PN 16 - WN FLANGE, PN 16

10016

DN	Collerette			Ø ext. D	Epais. C ₂	Hauteurs		Perçage		Portée de joint		Poids (kg)
	Ø A ₁	Ep. S	Ø N ₁			H ₂	H ₃	n x L	Ø K	Ø d ₁	f ₁	
10 au 40	Utiliser les dimensions PN 40 - Use dimensions of PN 40											
50	60.3	2.9	74	165	18	45	8	4 x 18	125	102	2	2.5
65	76.1	2.9	92	185	18	45	10	4 x 18	145	122	2	3.0
80	88.9	3.2	105	200	20	50	10	8 x 18	160	138	2	4.0
100	114.3	3.6	131	220	20	52	12	8 x 18	180	158	2	4.5
125	139.7	4.0	156	250	22	55	12	8 x 18	210	188	2	6.5
150	168.3	4.5	184	285	22	55	12	8 x 22	240	212	2	7.5
200	219.1	6.3	235	340	24	62	16	12 x 22	295	268	2	11.0
250	273.0	6.3	292	405	26	70	16	12 x 26	355	320	2	16.5
300	323.9	7.1	344	460	28	78	16	12 x 26	410	378	2	22.0
350	355.6	8.0	390	520	30	82	16	16 x 26	470	438	2	32.0
400	406.4	8.0	445	580	32	85	16	16 x 30	525	490	2	40.0
450	457.0	8.0	490	640	40	87	16	20 x 30	585	550	2	54.5
500	508.0	8.0	548	715	44	90	16	20 x 33	650	610	2	74.0
600	610.0	8.8	652	840	54	95	18	20 x 36	770	725	2	116.5

Construction suivant EN 1092-1 (≈ DIN 2633)

- acier carbone : réf. **10016**
- inox 316 L : réf. **10016 I**

Variantes : inox 304 L, ...
 Sur demande :
 - DN 700 au DN 2000
 - cote S pour sch. 40 ; 80 ; 160

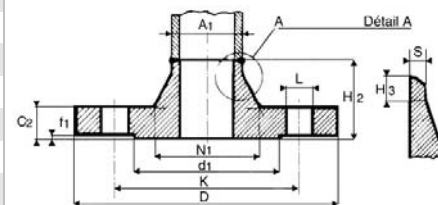

BRIDES A COLLERETTE A SOUDER EN BOUT - ACIER OU INOX - TYPE 11 B

WELDING NECK FLANGES - C. OR S. STEEL - TYPE 11 B

BRIDE ACIER A COLLERETTE PN 25 - WN FLANGE, PN 25

10025

DN	Collerette			Ø ext.	Epais.	Hauteurs			Perçage		Portée de joint		Poids (kg)
	Ø A ₁	Ep. S	Ø N ₁			D	C ₂	H ₂	H ₃	n x L	Ø K	Ø d ₁	
10 au 150	Utiliser les dimensions PN 40 Use dimensions of PN 40												
200	219.1	6.3	244	360	30	80	16	12 x 26	310	278	2	17.0	
250	273.0	7.1	298	425	32	88	18	12 x 30	370	335	2	24.0	
300	323.9	8.0	352	485	34	92	18	16 x 30	430	395	2	31.5	
350	355.6	8.0	398	555	38	100	20	16 x 33	490	450	2	48.0	
400	406.4	8.8	452	620	40	110	20	16 x 36	550	505	2	63.0	
450	457	8.8	500	670	46	110	20	20 x 36	600	555	2	75.5	
500	508	10.0	558	730	48	125	20	20 x 36	660	615	2	96.5	
600	610	11.0	660	845	58	125	20	20 x 39	770	720	2	138.6	
700	711	12.5	760	960	46	125	20	24 x 42	875	820	2	143.5	
800	813	14.2	864	1085	50	135	22	24 x 48	990	930	2	193.5	
900	914	16.0	968	1185	54	145	24	28 x 48	1090	1030	2	237.0	
1000	1016	17.5	1070	1320	58	155	24	28 x 56	1210	1140	2	310.5	

Construction suivant EN 1092-1 (≈ DIN 2634)

- acier carbone : réf. **10025**
- inox 316 L : réf. **10025 I**

Variantes : inox 304 L, ...

Sur demande :

- cote S pour sch. 40 ; 80 ; 160
- emboitements

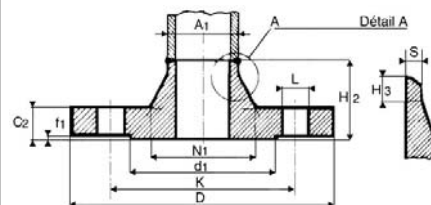

BRIDE ACIER A COLLERETTE PN 40 - WN FLANGE, PN 40

10040

DN	Collerette			Ø ext.	Epais.	Hauteurs			Perçage		Portée de joint		Poids (kg)
	Ø A ₁	Ep. S	Ø N ₁			D	C ₂	H ₂	H ₃	n x L	Ø K	Ø d ₁	
10	17.2	1.8	28	90	16	35	6	4 x 14	60	40	2	0.5	
15	21.3	2.0	32	95	16	38	6	4 x 14	65	45	2	1.0	
20	26.9	2.3	40	105	18	40	6	4 x 14	75	58	2	1.0	
25	33.7	2.6	46	115	18	40	6	4 x 14	85	68	2	1.0	
32	42.4	2.6	56	140	18	42	6	4 x 18	100	78	2	2.0	
40	48.3	2.6	64	150	18	45	7	4 x 18	110	88	2	2.0	
50	60.3	2.9	75	165	20	48	8	4 x 18	125	102	2	3.0	
65	76.1	2.9	90	185	22	52	10	8 x 18	145	122	2	4.0	
80	88.9	3.2	105	200	24	58	12	8 x 18	160	138	2	5.0	
100	114.3	3.6	134	235	24	65	12	8 x 22	190	162	2	6.5	
125	139.7	4.0	162	270	26	68	12	8 x 26	220	188	2	9.0	
150	168.3	4.5	192	300	28	75	12	8 x 26	250	218	2	11.5	
200	219.1	6.3	244	375	34	88	16	12 x 30	320	285	2	21.0	
250	273.0	7.1	306	450	38	105	18	12 x 33	385	345	2	34.0	
300	323.9	8.0	362	515	42	115	18	16 x 33	450	410	2	47.5	
350	355.6	8.8	408	580	46	125	20	16 x 36	510	465	2	69.0	
400	406.4	11.0	462	660	50	135	20	16 x 39	585	535	2	98.0	
450	457.0	12.5	500	685	57	135	20	20 x 39	610	560	2	105.08	
500	508.0	14.2	562	755	57	140	20	20 x 42	670	615	2	130.5	
600	610.0	16.0	666	890	72	150	20	20 x 48	795	735	2	211.5	

Construction suivant EN 1092-1 (≈ DIN 2635)

- acier carbone : réf. **10040**
- inox 316 L : réf. **10040 I**

Variantes : inox 304 L, ...

Sur demande :

- cote S pour sch. 40 ; 80 ; 160
- emboitements

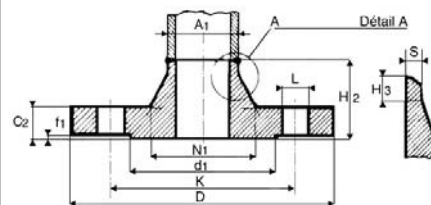

BRIDE ACIER A COLLERETTE PN 63 - WN FLANGE, PN 63

10063

DN	Collerette			Ø ext.	Epais.	Hauteurs			Perçage		Portée de joint		Poids (kg)
	Ø A ₁	Ep. S	Ø N ₁			D	C ₂	H ₂	H ₃	n x L	Ø K	Ø d ₁	
10 au 40	Utiliser les dimensions PN 40 Use dimensions of PN 40												
50	60.3	2.9	82	180	26	62	10	4 x 22	135	102	2	4.5	
65	76.1	3.2	98	205	26	68	12	8 x 22	160	122	2	5.5	
80	88.9	3.6	112	215	28	72	12	8 x 22	170	138	2	6.5	
100	114.3	4.0	138	250	30	78	12	8 x 26	200	162	2	9.5	
125	139.7	4.5	168	295	34	88	12	8 x 30	240	188	2	14.5	
150	168.3	5.6	202	345	36	95	12	8 x 33	280	218	2	21.5	
200	219.1	7.1	256	415	42	110	16	12 x 36	345	285	2	34.0	
250	273.0	8.8	316	470	46	125	18	12 x 36	400	345	2	48.0	
300	323.9	11.0	372	530	52	140	18	16 x 36	460	410	2	67.5	
350	355.6	12.5	420	600	56	150	20	16 x 39	525	465	2	97.5	
400	406.4	14.2	475	670	60	160	20	16 x 42	585	535	2	129.0	

Construction suivant EN 1092-1 (≈ DIN 2636)

- acier carbone : réf. **10063**

Variantes : inox 316 L, 304 L ...

Sur demande :

- cote S pour sch. 40 ; 80 ; 160
- emboitements

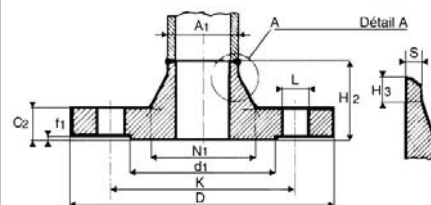

BRIDE A COLLERETTE A SOUDER EN BOUT TYPE 11 B

WELDING NECK FLANGE TYPE 11 B

BRIDE A COLLERETTE ACIER PN 100 - WN FLANGE, PN 100

10100

DN	Collerette			Ø ext. D	Epais. C ₂	Hauteurs		Perçage		Portée de joint		Poids (kg)	
	Ø A ₁	Ep. S	Ø N ₁			H ₂	H ₃	n x L	Ø K	Ø d ₁	f ₁		
10	17.2	1.8	32	100	20	45	6	4 x 14	70	40	2	1.0	Construction suivant EN 1092-1 Acier carbone
15	21.3	2.0	34	105	20	45	6	4 x 14	75	45	2	1.0	Variantes : inox 316 L, 304 L, ...
20	26.9	2.6	42	130	22	48	8	4 x 18	90	58	2	2.0	Sur demande :
25	33.7	2.6	52	140	24	58	8	4 x 18	100	68	2	2.5	- côte S pour sch. 40 ; 80 ; 160
32	42.4	2.9	62	155	24	60	8	4 x 22	110	78	2	3.0	- DN 400 et DN 500
40	48.3	2.9	70	170	26	62	10	4 x 22	125	88	2	4.0	
50	60.3	3.2	90	195	28	68	10	4 x 26	145	102	2	6.0	
65	76.1	3.6	108	220	30	76	12	8 x 26	170	122	2	7.5	
80	88.9	4.0	120	230	32	78	12	8 x 26	180	138	2	9.0	
100	114.3	5.0	150	265	36	90	12	8 x 30	210	162	2	13.0	
125	139.7	6.3	180	315	40	105	12	8 x 33	250	188	2	21.0	
150	168.3	7.1	210	355	44	115	12	12 x 33	290	218	2	28.0	
200	219.1	10.0	278	430	52	130	16	12 x 36	360	285	2	50.0	
250	273.0	12.5	340	505	60	157	18	12 x 39	430	345	2	81.0	
300	323.9	14.2	400	585	68	170	18	16 x 42	500	410	2	117.97	
350	355.6	16.0	460	655	74	189	20	16 x 48	560	465	2	167.25	

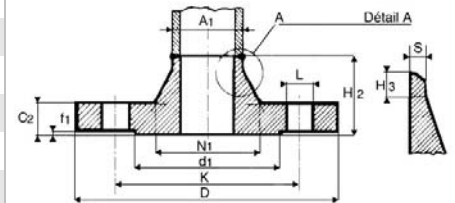
**ATTENTION :**

Ne pas confondre ces brides **PN 100** avec les brides **ISO PN 100** (= classe 600 selon ASME B 16.5)

BRIDE A COLLERETTE A VISSER TYPE 13 B

THREADED NECK FLANGE TYPE 13 B

BRIDE A COLLERETTE TARAUEE ACIER PN 16 - THREADED NECK FLANGE, PN 16

10110 T

DN	Collerette Ø N ₂	Ø ext. D	Epaisseur C ₁	Hauteur H ₁	Perçage		Portée de joint		Poids (kg)	
					n x L	Ø K	Ø d ₁	f ₁		
10	30	90	14	20	4 x 14	60	40	2	0.54	Construction suivant DIN 2566 Acier carbone
15	35	95	14	20	4 x 14	65	45	2	0.61	
20	45	105	16	24	4 x 14	75	58	2	0.91	Portée de Joint Surélevée (PJS)
25	52	115	16	24	4 x 14	85	68	2	1.10	
32	60	140	16	26	4 x 18	100	78	2	1.60	
40	70	150	16	26	4 x 18	110	88	2	1.78	
50	85	165	18	28	4 x 18	125	102	2	2.43	
65	105	185	18	32	4 x 18	145	122	2	3.18	
80	118	200	20	34	8 x 18	160	138	2	4.12	
100	140	220	20	38	8 x 18	180	158	2	4.47	
125	168	250	22	40	8 x 18	210	188	2	6.13	
150	195	285	22	44	8 x 22	240	212	2	7.92	

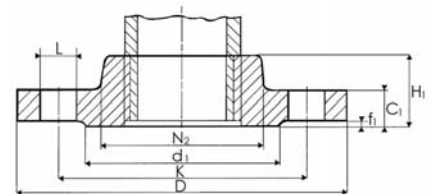

BRIDES PLATES A SOUDER TYPE 01 A / BRIDES PLEINES TYPE 05 A

WELDING PLATE FLANGES TYPE 01 A / BLIND FLANGES TYPE 05 A

BRIDE PLATE A SOUDER & BRIDE PLEINE PN 10 - PLATE & BLIND FLANGE PN 10

11010 - 11060

DN	Ø ext.		Perçage		TYPE 01 A			TYPE 05 A		
	D	n x L	Ø K	C ₁	B ₁	Poids (kg)	C ₄	G max.	Poids (kg)	
10	90	4 x 14	60	14	18.0	0.6	16	-	1.0	
15	95	4 x 14	65	14	22.0	0.5	16	-	1.0	
20	105	4 x 14	75	16	27.5	1.0	18	-	1.0	
25	115	4 x 14	85	16	34.5	1.0	18	-	1.5	
32	140	4 x 18	100	18	43.5	2.0	18	-	2.0	
40	150	4 x 18	110	18	49.5	2.0	18	-	2.5	
50	165	4 x 18	125	19	61.5	2.5	18	-	3.0	
65	185	4 x 18	145	20	77.5	3.0	18	55	3.5	
80	200	8 x 18	160	20	90.5	3.5	20	70	4.5	
100	220	8 x 18	180	22	116.0	4.5	20	90	5.5	
125	250	8 x 18	210	22	141.5	5.5	22	115	8.0	
150	285	8 x 22	240	24	170.5	7.0	22	140	10.5	
200	340	8 x 22	295	24	221.5	9.5	24	190	16.5	
250	395	12 x 22	350	26	276.5	12.0	26	235	24.0	
300	445	12 x 22	400	26	327.5	13.5	26	285	31.0	
350	505	16 x 22	460	28	359.5	20.5	26	330	39.5	
400	565	16 x 26	515	32	411.0	27.5	26	380	49.5	
450	615	20 x 26	565	36	462.0	33.5	28	425	63.0	
500	670	20 x 26	620	38	513.5	40.0	28	475	75.5	
600	780	20 x 30	725	42	616.5	54.5	34	575	124.0	
700	895	24 x 30	840	40 *	716 *	66 *	38	670	182.5	
800	1015	24 x 33	950	44 *	818 *	91 *	42	770	260.0	
900	1115	28 x 33	1050	48 *	920 *	108 *	46	860	344.0	
1000	1230	28 x 36	1160	50 *	1022 *	133 *	52	960	473.5	
1200	1455	32 x 39	1380	54 *	1226 *	188 *	60	1160	765.0	

* selon DIN 2576 pour DN ≥ 700



Construction suivant EN 1092-1 (≈ DIN 2576)

- Bride plate à souder acier : réf. **11010**

Variantes de brides plates :

- Bride amincie : réf. **11010 A**
- Bride inox 316 L : réf. **11011 I**

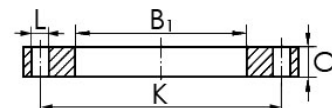

Construction suivant EN 1092-1 (≈ DIN 2527)

- Bride pleine en acier : réf. **11060**

Variante :

- Bride pleine inox 316 L : réf. **11060 I**

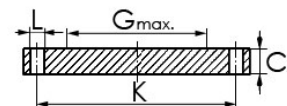

BRIDE PLATE A SOUDER & BRIDE PLEINE ISO PN 16 - PLATE & BLIND FLANGE ISO PN 16

11016 - 11065

DN	Ø ext.		Perçage		TYPE 01 A			TYPE 05 A		
	D	n x L	Ø K	C ₁	B ₁	Poids (kg)	C ₄	G max.	Poids (kg)	
10	90	4 x 14	60	14	18.0	0.6	16	-	1.0	
15	95	4 x 14	65	14	22.0	0.5	16	-	1.0	
20	105	4 x 14	75	16	27.5	1.0	18	-	1.0	
25	115	4 x 14	85	16	34.5	1.0	18	-	1.5	
32	140	4 x 18	100	18	43.5	2.0	18	-	2.0	
40	150	4 x 18	110	18	49.5	2.0	18	-	2.5	
50	165	4 x 18	125	19	61.5	2.5	18	-	3.0	
65	185	4 x 18	145	20	77.5	3.0	18	55	3.5	
80	200	8 x 18	160	20	90.5	3.5	20	70	4.5	
100	220	8 x 18	180	22	116.0	4.5	20	90	5.5	
125	250	8 x 18	210	22	141.5	5.5	22	115	8.0	
150	285	8 x 22	240	24	170.5	7.0	22	140	10.5	
200	340	12 x 22	295	26	221.5	9.5	24	190	16.5	
250	405	12 x 26	355	29	276.5	14.0	26	235	25.0	
300	460	12 x 26	410	32	327.5	19.0	28	285	35.0	
350	520	16 x 26	470	35	359.0	28.0	30	330	48.0	
400	580	16 x 30	525	38	411.0	36.0	32	380	63.5	
450	640	20 x 30	585	42	462.0	46.0	40	425	96.5	
500	715	20 x 33	650	46	513.5	64.0	44	475	133.0	
600	840	20 x 36	770	52	616.5	96.0	54	575	226.5	
700	910	24 x 36	840	44 *	716 *	77 *	48	670	236.0	
800	1025	24 x 39	950	50 *	818 *	106 *	52	770	325.0	
900	1115	28 x 39	1050	54 *	920 *	125 *	58	860	437.5	
1000	1255	28 x 42	1170	60 *	1022 *	178 *	64	960	602.0	
1200	1485	32 x 48	1390	68 *	1226 *	263 *	76	1160	999.0	

* selon DIN 2502 pour DN ≥ 700



Construction suivant EN 1092-1

- Bride plate à souder acier : réf. **11016**

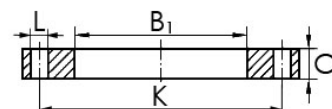

Construction suivant EN 1092-1 (≈ DIN 2527)

- Bride pleine acier : réf. **11065**

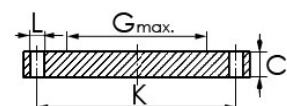

BRIDES PLEINES TYPE 05 A

BLIND FLANGES TYPE 05 A

BRIDES PLEINES PN 25 - BLIND FLANGES PN 25

11070

DN	Ø ext.	Perçage		Epaisseur C ₄	Ø d'épaulement G _{max.}	Poids (kg)	Construction suivant EN 1092-1 (≈ DIN 2527) Acier carbone Variantes : • Inox 304 L, 316 L, UB6, ... • Emboitements
	D	n x L	Ø K				
10 au 150	Utiliser les dimensions PN 40 <i>Use dimensions of PN 40</i>						
200	360	12 x 26	310	30	190	22.5	
250	425	12 x 30	370	32	235	33.5	
300	485	16 x 30	430	34	285	46.5	
350	555	16 x 33	490	38	332	68.0	
400	620	16 x 36	550	40	380	89.5	

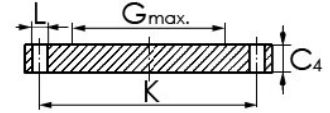

BRIDES PLEINES PN 40 - BLIND FLANGES PN 40

11075

DN	Ø ext.	Perçage		Epaisseur C ₄	Ø d'épaulement G _{max.}	Poids (kg)	Construction suivant EN 1092-1 (≈ DIN 2527) Acier carbone Variantes : • Inox 304, 316 L, UB6, ... • Emboitements
	D	n x L	Ø K				
10	90	4 x 14	60	16	-	1.0	
15	95	4 x 14	65	16	-	1.0	
20	105	4 x 14	75	18	-	1.0	
25	115	4 x 14	85	18	-	1.5	
32	140	4 x 18	100	18	-	2.0	
40	150	4 x 18	110	18	-	2.5	
50	165	4 x 18	125	20	-	3.0	
65	185	8 x 18	145	22	55	4.5	
80	200	8 x 18	160	24	70	5.5	
100	235	8 x 22	190	24	90	7.5	
125	270	8 x 26	220	26	115	11.0	
150	300	8 x 26	250	28	140	14.5	
200	375	12 x 30	320	36	190	29.0	
250	450	12 x 33	385	38	235	44.5	
300	515	16 x 33	450	42	285	64.0	
350	580	16 x 36	510	46	330	89.5	
400	660	16 x 39	585	50	380	127.0	
450	685	30 x 39	610	57	425	154.0	
500	755	20 x 42	670	57	475	188.0	
600	890	20 x 48	795	72	575	331.0	



Construction suivant EN 1092-1 (≈ DIN 2527)
Acier carbone

Variantes :
• Inox 304, 316 L, UB6, ...
• Emboitements

Execution acc. to EN 1092-1 (≈ DIN 2527)
Carbon steel construction

Alternates :
• 304, 316 L, UB6, ...
• Male & Female facings

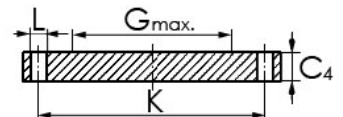

BRIDES TOURNANTES - COLLETS A COLLERETTE - COLLETS PLATS

LOOSE PLATE FLANGES - WN COLLARS - WELDING FLAT COLLARS

BRIDES PLATES TOURNANTES ACIER ISO PN 10 - LOOSE PLATE FLANGES ISO PN 10

11002 - 11003

DN	Alésage (mm)		Ø ext.	Epaisseur	Perçage		Chanfrein	Kg / pc	
	B ₂ -11002	B ₃ -11003	D (mm)	C ₁ (mm)	n x L	Ø K (mm)	e (mm)	TYPE 02A	TYPE 04 A
10	21	31	90	14	4 x 14	60	3	0.5	0.5
15	25	35	95	14	4 x 14	65	3	0.5	0.5
20	31	42	105	16	4 x 14	75	4	1.0	1.0
25	38	49	115	16	4 x 14	85	4	1.0	1.0
32	47	59	140	18	4 x 18	100	5	2.0	1.5
40	53	67	150	18	4 x 18	110	5	2.0	2.0
50	65	77	165	19	4 x 18	125	5	2.5	2.5
65	81	96	185	20	4 x 18	145	6	3.0	3.0
80	94	108	200	20	8 x 18	160	6	3.5	3.0
100	120	134	220	22	8 x 18	180	6	4.5	4.0
125	145	162	250	22	8 x 18	210	6	5.5	4.5
150	174	188	285	24	8 x 22	240	6	7.0	6.0
200	226	240	340	24	8 x 22	295	6	9.0	8.0
250	281	294	395	26	12 x 22	350	8	11.5	10.0
300	333	348	445	26	12 x 22	400	8	13.0	11.5
350	365	400	505	28	16 x 22	460	8	19.5	15.0
400	416	450	565	32	16 x 26	515	8	26.5	21.0
450	467	498	615	36	20 x 26	565	8	32.5	26.0
500	519	550	670	38	20 x 26	620	8	39.0	31.0
600	622	650	780	42	20 x 30	725	8	52.5	43.5

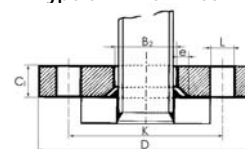
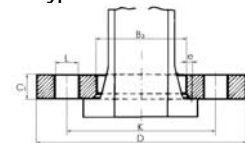

Norme EN 1092-1 (≈ DIN 2642)

Acier : réf. **11002** : 316 L : réf. **11002 I**Variantes : 304 L, UB6, ...
PN 16, PN 40**Type 02 A** - réf. **11002****Type 04 A** - réf. **11003**

BRIDES TOURNANTES POINT BLEU ISO PN 10 - LAP JOINT FLANGES ISO PN 10

11004 - 11004 I

DN	Dimensions							Perçage		Kg / pc	Gain de poids (1)
	a (mm)	D (mm)	E (mm)	F (mm)	G (mm)	r ₁ (mm)	r ₃ (mm)	n x L	Ø K		
15	3	95	11.5	24	38	3	3	4 x 13.5	65	0.20	70 %
20	3	105	14	30	48	3	3	4 x 13.5	75	0.25	70 %
25	3	115	16	38	53	3	3	4 x 13.5	85	0.30	62 %
32	3	140	16.5	46	68	3	3.5	4 x 17.5	100	0.45	62 %
40	4	150	18	54	77	3	3.5	4 x 17.5	110	0.62	70 %
50	4	165	20	65	91	3	4	4 x 17.5	125	0.90	65 %
65	5	185	22	81	108	4.5	5	4 x 17.5	145	1.20	65 %
80	5	200	23	94	123	4.5	5	8 x 17.5	160	1.30	65 %
100	6	220	24	119	141	5	5	8 x 17.5	180	1.75	60 %
125	6	250	25.5	145	168	4.5	5	8 x 17.5	210	2.20	50 %
150	6	285	27	173	192	4.5	5	8 x 21.5	240	2.70	50 %
200	8	340	31	225	245	5	5	8 x 21.5	295	4.60	50 %

Bride tournante emboutie PN 10 / 200°C
Pour collet à souder ISO ou métrique
Norme EN 1092-1 **type 2** (≈DIN 2642)

- réf. **11004** : acier bichromaté
- réf. **11004 I** : inox 304

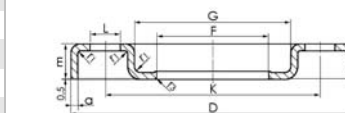

(1) Par rapport à une bride tournante standard

COLLETS A COLLERETTE A SOUDER - WELDING NECK COLLARS

110516 - 110540

DN	Ø A (mm)	réf. 110516 PN 10/16				réf. 110540 PN 25/40			
		d ₁ (mm)	F (mm)	H ₂ (mm)	Kg / pc	d ₁ (mm)	F (mm)	H ₂ (mm)	Kg / pc
10	17.2	40	12	35	0.14	40	12	35	0.16
15	21.3	45	12	38	0.18	45	12	38	0.21
20	26.9	58	14	40	0.32	58	14	40	0.40
25	33.7	68	14	40	0.42	68	14	40	0.48
32	42.4	78	14	42	0.55	78	14	42	0.60
40	48.3	88	14	45	0.65	88	14	45	0.80
50	60.3	102	16	45	0.95	102	16	48	1.10
65	76.1	122	16	45	1.20	122	16	52	1.50
80	88.9	138	16	50	1.75	138	18	58	2.0
100	114.3	158	18	52	2.20	162	20	65	2.90

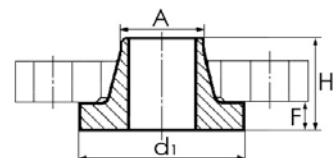
Norme EN 1092-1 **type 34**
Assemblage sur bride type 11003
Acier carbone
Variantes : inox 304 L, 316 L, ...

COLLETS PLATS A SOUDER - WELDING FLAT COLLARS

110616 - 110640

DN	Ø A (mm)	B ₁ (mm)	réf. 110616 PN 10/16			réf. 110640 PN 25/40		
			d ₁ (mm)	F (mm)	Kg / pc	d ₁ (mm)	F (mm)	Kg / pc
10	17.2	18.0	40	10	0.09	40	12	0.11
15	21.3	22.0	45	10	0.11	45	12	0.13
20	26.9	27.5	58	12	0.20	58	14	0.22
25	33.7	34.5	68	12	0.25	68	14	0.30
32	42.4	43.5	78	12	0.32	78	14	0.37
40	48.3	49.5	88	12	0.40	88	14	0.46
50	60.3	61.5	102	16	0.58	102	16	0.67
65	76.1	77.5	122	16	0.77	122	16	0.88
80	88.9	90.5	138	16	0.95	138	18	1.07
100	114.3	116.0	158	18	1.20	162	20	1.50
10	17.2	18.0	40	10	0.09	40	12	0.11

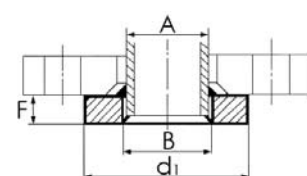
Norme EN 1092-1 **type 32**
Assemblage sur bride type 11002
Acier carbone
Variantes : inox 304 L, 316 L, ...

COLLETS INOX 316 L A SOUDER STAINLESS STEEL 316 L COLLARS

COLLET MINCE PN 10 - THIN COLLAR PN 10

11007

D x e	d (mm)	g (mm)	h (mm)	D x e	d (mm)	g (mm)	h (mm)	D x e	d (mm)	g (mm)	h (mm)
17.2 x 2	13.2	40	6	88.9 x 2	84.9	138	13	254.0 x 2	250.0	320	22
21.3 x 2	17.3	45	6	88.9 x 3	82.9	138	13	256.0 x 3	250.0	320	22
24.0 x 2	20.0	60	7	104.0 x 2	100.0	158	12	273.0 x 2	269.0	320	22
26.9 x 2	22.9	58	7	114.3 x 2	110.3	158	12	273.0 x 3	267.0	320	22
33.7 x 2	29.7	68	9	114.3 x 3	108.8	158	12	304.0 x 2	300.0	370	22
34.0 x 2	30.0	80	9	129.0 x 2	125.0	186	12	306.0 x 3	300.0	370	22
39.0 x 2	35.0	80	9	139.7 x 2	135.7	186	14	323.9 x 2	319.9	370	23
42.4 x 2	38.4	78	10	139.7 x 3	133.7	186	14	323.9 x 3	317.9	370	23
44.0 x 2	40.0	90	10	154.0 x 2	150.0	212	18	354.0 x 2	350.0	430	23
48.3 x 2	44.3	88	10	168.3 x 2	164.3	212	18	355.6 x 3	349.6	430	23
54.0 x 2	50.0	105	12	168.3 x 3	162.3	212	18	406.4 x 3	400.4	482	23
60.3 x 2	56.3	102	12	204.0 x 2	200.0	268	18	457.2 x 4	449.2	532	40
76.1 x 2	72.1	122	12	206.0 x 3	200.0	268	18	508.0 x 4	500.0	585	40
76.1 x 3	70.1	122	12	219.1 x 2	215.1	268	22				
84.0 x 2	80.0	140	12	219.1 x 3	213.1	268	22				

Collet mince embouti suivant NFE 29 251

- PN 10
- Inox 316 L (inox 304 L sur demande)
- Pour tubes ISO et métriques

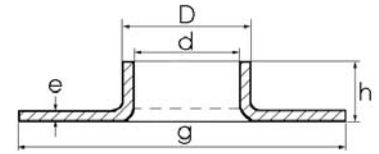

COLLET EPAIS USINE PN 10 - THICK MACHINED COLLAR PN 10

11007 E

DN	Ø d ₁ (mm)	Ø d ₂ (mm)	s (mm)		e (mm)	g (mm)	h (mm)	r (mm)
			de	à				
10	17.2	18.4	1.6	2	3	42	7	3
15	21.3	22.5	1.6	2	3	47	7	3
20	26.9	27.2	1.6	2	3	58	9	3
25	33.7	37	1.6	3	4	68	10.5	4
32	42.4	46	1.6	3.2	4	78	14	4
40	48.3	51	1.6	3.2	4	88	14	4
50	60.3	63.5	1.6	3.6	4	102	16	4
65	76.1	79.5	1.6	3.6	5	122	19	4
80	88.9	93.5	2	4	5	133	23	4
100	114.3	117.5	2	4.5	5	158	25	4
125	139.7	149	2	4.5	5	184	26	4
150	168.3	172	2	4.5	5	212	29	4
200	219.1	224	2	4.5	5	268	32	4
250	273.0	277	2	4.5	5	320	32	5
300	323.9	328	3	5	5	370	36	5

Collet épais usiné

- Dimensions dérivées de la norme NFE 29 251
- PN 10
- Inox 316 L (inox 304 L sur demande)
- Pour tubes ISO et métriques

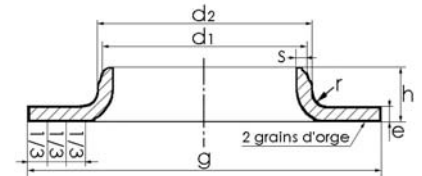

COLLET EMBOUTI TUBE SCH. 40S - PRESSED COLLAR SCH. 40S PIPE

11008

DN	Ø d ₁ (mm)	s (mm)	e (mm)	g (mm)	h (mm)
15	1/2	21.3	2.77	45	7
20	3/4	26.9	2.88	58	9
25	1	33.4	3.38	68	10.5
32	1-1/4	42.4	3.56	78	14
40	1-1/2	48.3	3.68	88	14
50	2	60.3	3.91	102	16
65	2-1/2	73.0	5.16	122	19
80	3	88.9	5.49	138	23
100	4	114.3	6.02	158	26
125	5	141.3	6.55	188	26
150	6	168.3	7.11	212	29

- Collet embouti pour tube sch. 40S (tube sch. 10S, 80S, etc. sur demande)
- Inox 316 L (inox 304 L sur demande)

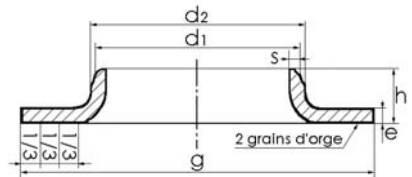

COLLETS "STUB END" SELON ASME B 16.9 / MSS-SP 43 - "STUB END" COLLARS

11009

DN	Ø d ₁ (mm)	e (mm)		g (mm)	h (mm)	r (mm)	
		sch. 10S	sch. 40S			TYPE A	TYPE C
1/2	21.3	2.11	2.77	34.9	51	3	0.8
3/4	26.7	2.11	2.87	42.8	51	3	0.8
1	33.4	2.77	3.38	50.8	51	3	0.8
1-1/4	42.2	2.77	3.56	63.5	51	5	0.8
1-1/2	48.3	2.77	3.68	73.0	51	6	0.8
2	60.3	2.77	3.91	92.1	63	8	0.8
2-1/2	73.0	3.05	5.16	104.8	63	8	0.8
3	88.9	3.05	5.49	127.0	63	10	0.8
4	114.3	3.05	6.02	157.2	76	11	0.8
5	141.3	3.40	6.55	185.7	76	11	1.6
6	168.3	3.40	7.11	215.9	89	13	1.6
8	219.1	3.76	8.18	269.9	102	13	1.6
10	273.0	4.19	9.27	323.9	127	13	1.6

Collets "stub end" ANSI :

- TYPE A série courte : réf. 11009 A
- TYPE C série courte : réf. 11009 (longueur courte selon MSS SP 43)
- Inox 316 L (inox 304 L sur demande)

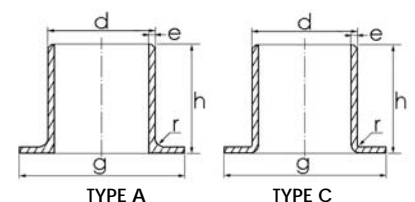

DIMENSIONS DES PORTEES DE JOINT - ASME B 16.5 FLANGE FACINGS DIMENSIONS - ASME B 16.5

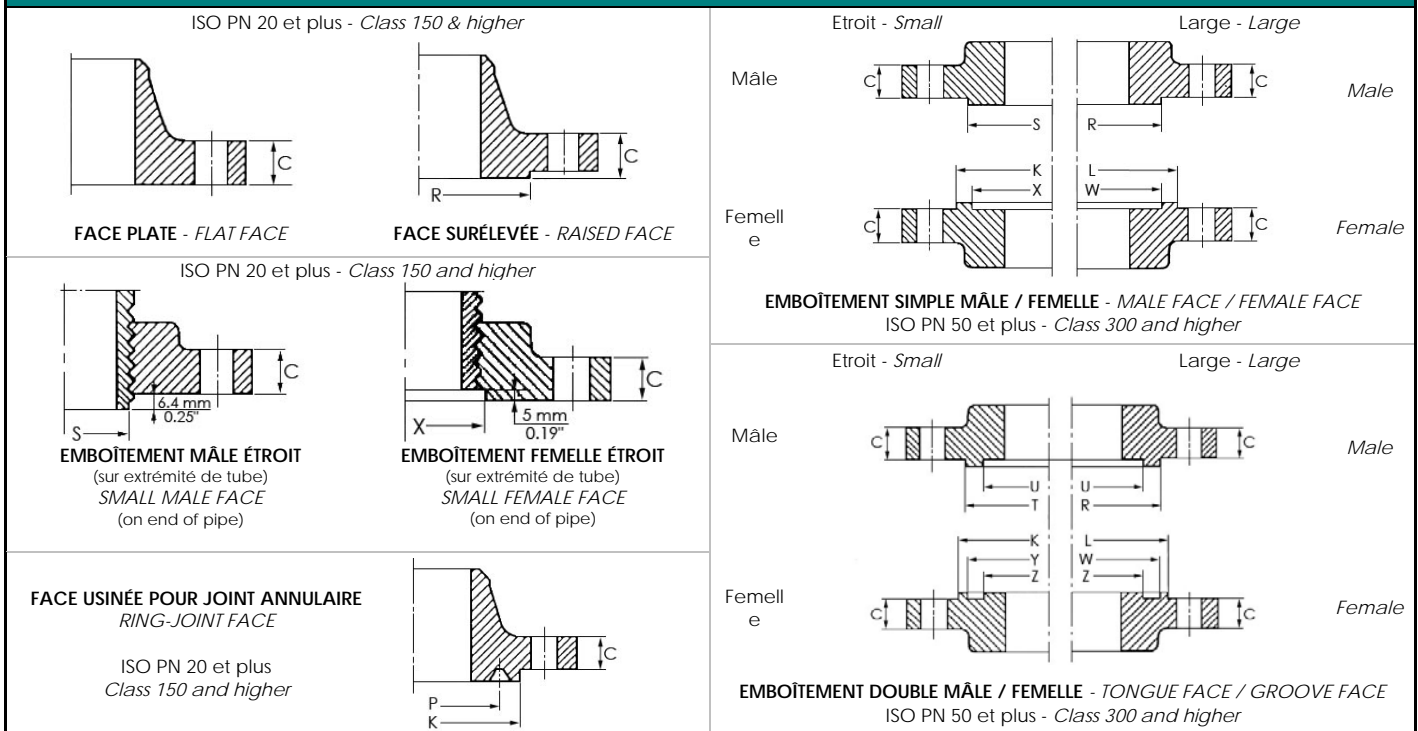

DIMENSIONS POUR TOUTES CLASSES DE PRESSION - DIMENSIONS FOR ALL PRESSURE CLASSES

DN		K (mm)	L (mm)	R (mm)	S (mm)	T (mm)	U (mm)	W (mm)	X (mm)	Y (mm)	Z (mm)
15	1/2	44.5	46.0	35.0	18.3	35.1	25.4	36.6	19.8	36.6	23.9
20	3/4	52.3	53.8	42.9	23.9	42.9	33.2	44.4	25.4	44.4	31.7
25	1	57.2	62.0	50.8	30.2	47.7	38.1	52.3	31.7	49.2	36.6
32	1-1/4	66.5	74.7	63.5	38.1	57.2	47.7	65.0	39.6	58.7	46.0
40	1-1/2	73.2	84.1	73.1	44.5	63.5	53.8	74.7	46.0	65.0	52.3
50	2	92.0	103.1	91.9	57.2	82.6	73.2	93.7	58.7	84.1	71.4
65	2-1/2	104.6	115.8	104.6	68.3	95.3	85.9	106.4	69.9	96.8	84.1
80	3	127.0	138.2	127.0	84.1	117.3	108.0	128.5	85.9	119.1	106.4
100	4	157.2	168.1	157.2	109.5	144.6	131.8	158.9	111.3	146.1	130.0
125	5	185.7	196.9	185.7	136.7	173.0	160.3	186.5	138.2	174.8	158.8
150	6	215.9	227.0	215.9	162.1	203.2	190.5	217.4	163.6	204.7	183.0
200	8	269.7	281.0	269.7	212.8	254.0	238.3	271.5	214.4	255.5	236.5
250	10	323.9	335.0	323.8	266.7	304.8	285.8	325.4	268.2	306.3	284.2
300	12	381.0	392.2	381.0	317.5	362.0	342.9	382.5	319.0	363.5	341.4
350	14	412.8	424.0	412.8	349.3	393.7	374.7	414.3	350.8	395.2	373.1
400	16	469.9	481.0	469.9	400.1	447.5	425.5	471.4	401.6	449.3	424.0
450	18	533.4	544.6	533.4	450.8	511.0	489.0	534.9	452.4	512.8	487.4
500	20	584.2	595.4	584.2	501.7	558.8	533.4	585.7	503.2	560.3	531.9
600	24	692.2	703.3	692.2	603.3	666.8	641.4	693.7	604.8	668.3	639.8

DIMENSIONS POUR FACES DE BRIDES A JOINT ANNULAIRE - DIMENSIONS OF RING-JOINT FACINGS

DN		Série 150 lbs			Séries 300 - 600 lbs			Série 900 lbs			Série 1500 lbs			Série 2500 lbs		
		K (mm)	P (mm)	N° joint	K (mm)	P (mm)	N°	K (mm)	P (mm)	N°	K (mm)	P (mm)	N°	K (mm)	P (mm)	N° joint
15	1/2				50.8	34.14	R11	60.5	39.67	R12	60.5	39.67	R12	65.0	42.88	R13
20	3/4				63.5	42.28	R13	66.5	44.45	R14	66.5	44.45	R14	73.2	50.80	R16
25	1	63.5	47.62	R15	69.9	50.80	R16	71.4	50.80	R16	71.4	50.80	R16	82.6	60.32	R18
32	1-1/4	73.2	57.15	R17	79.2	60.32	R18	81.0	60.32	R18	81.0	60.32	R18	101.6	72.24	R21
40	1-1/2	82.5	65.07	R19	90.4	68.28	R20	91.9	68.28	R20	91.9	68.28	R20	114.3	82.55	R23
50	2	101.6	82.55	R22	108.0	82.55	R23	123.9	95.25	R24	123.9	95.25	R24	133.4	101.60	R26
65	2-1/2	120.7	101.60	R25	127.0	101.60	R26	136.7	107.95	R27	136.7	107.95	R27	149.4	111.12	R28
80	3	133.4	114.30	R29	146.1	123.83	R30	155.4	123.82	R31	168.1	136.52	R35	168.1	127.00	R32
100	4	171.5	149.22	R36	174.8	149.22	R37	180.8	149.22	R37	193.5	161.92	R39	203.2	157.18	R38
125	5	193.5	171.45	R40	209.6	180.98	R41	215.9	180.98	R41	228.6	193.68	R44	241.3	190.50	R42
150	6	219.0	193.68	R43	241.3	211.12	R45	241.3	211.12	R45	248.0	211.12	R46	279.4	228.60	R47
200	8	273.0	247.65	R48	301.8	269.88	R49	307.8	269.88	R49	318.0	269.88	R50	339.9	279.40	R51
250	10	330.2	304.80	R52	355.6	323.85	R53	362.0	323.85	R53	371.0	323.85	R54	425.5	342.90	R55
300	12	406.4	381.00	R56	412.8	381.00	R57	419.1	381.00	R57	438.0	381.00	R58	495.3	406.40	R60
350	14	425.5	396.88	R59	457.2	419.10	R61	466.9	419.10	R62	489.0	419.10	R63			
400	16	482.6	454.02	R64	508.0	469.90	R65	523.7	469.90	R66	546.0	469.90	R67			
450	18	546.1	517.52	R68	574.5	533.40	R69	593.9	533.40	R70	613.0	533.40	R71			
500	20	596.9	558.80	R72	635.0	584.20	R73	647.7	584.20	R74	673.0	584.20	R75			
600	24	711.2	673.10	R76	749.3	692.15	R77	771.7	692.15	R78	794.0	692.15	R79			

BRIDES WELDING NECK A FACE SURELEVEE - ASME B 16.5
WELDING NECK FLANGES RAISED FACE - ASME B 16.5

BRIDES WELDING NECK ISO PN 20 RF - WN FLANGES CLASS 150 # RF

10150

DN		Collerette		Ø ext. D	Ep. C	Hauteurs		Perçage		Portée de joint Ø R	Poids (kg)
		Ø A	Ø N			H ₂	H ₃	n x L	Ø K		
15	1/2	21.3	30	89	11.2	48	6.4	4 x 15.8	60.3	34.9	0.6
20	3/4	26.7	38	99	12.7	52	6.4	4 x 15.8	69.8	42.9	0.8
25	1	33.4	49	108	14.3	56	6.4	4 x 15.8	79.4	50.8	1.1
32	1-1/4	42.2	59	117	15.7	57	6.4	4 x 15.8	88.9	63.5	1.4
40	1-1/2	48.3	65	127	17.5	62	6.4	4 x 15.8	98.4	73.0	1.8
50	2	60.3	78	152	19.1	63	6.4	4 x 19.0	120.6	92.1	2.7
65	2-1/2	73.0	90	178	22.3	70	6.4	4 x 19.0	139.7	104.8	4.0
80	3	88.9	108	190	23.9	70	6.4	4 x 19.0	152.4	127.0	4.5
100	4	114.3	135	229	23.9	76	6.4	8 x 19.0	190.5	157.2	7.0
125	5	141.3	164	254	23.9	89	6.4	8 x 22.2	215.9	185.7	8.6
150	6	168.3	192	279	25.4	89	6.4	8 x 22.2	241.3	215.9	10.8
200	8	219.1	246	343	28.5	102	6.4	8 x 22.2	298.4	269.9	18.0
250	10	273.0	305	406	30.2	102	6.4	12 x 25.4	362.0	323.8	24.0
300	12	323.9	365	483	31.8	114	6.4	12 x 25.4	431.8	381.0	37.0
350	14	355.6	400	533	35.0	127	6.4	12 x 28.5	476.2	412.8	47.0
400	16	406.4	457	597	36.6	127	6.4	16 x 28.5	539.8	469.9	58.0
450	18	457.0	505	635	39.7	140	6.4	16 x 31.8	577.8	533.4	64.0
500	20	508.0	559	698	42.9	144	6.4	20 x 31.8	635.0	584.2	77.0
600	24	610.0	664	813	47.7	152	6.4	20 x 35.0	749.3	692.2	118.0



ISO PN 20 - Série 150 lbs - ASME B 16.5

- Acier : réf. 10150
 - inox 316 L : réf. 10150 I
- Variantes : aciers alliés, inox 304 L, ...
 Standard : pour tube épaisseur sch. 40
 Autres épaisseurs de tube sur demande

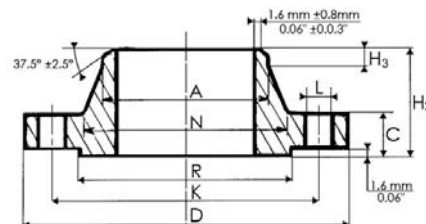

BRIDES WELDING NECK ISO PN 50 RF - WN FLANGES CLASS 300 # RF

10300

DN		Collerette		Ø ext. D	Ep. C	Hauteurs		Perçage		Portée de joint Ø R	Poids (kg)
		Ø A	Ø N			H ₂	H ₃	n x L	Ø K		
15	1/2	21.3	38	95	14.2	52	6.4	4 x 15.8	66.7	34.9	1.5
20	3/4	26.7	48	117	15.7	57	6.4	4 x 19.0	82.6	42.9	1.8
25	1	33.4	54	124	17.5	62	6.4	4 x 19.0	88.9	50.8	2.0
32	1-1/4	42.2	63	133	19.0	65	6.4	4 x 19.0	98.4	63.5	2.5
40	1-1/2	48.3	70	156	20.6	68	6.4	4 x 22.2	114.3	73.0	3.5
50	2	60.3	84	165	22.4	70	6.4	8 x 19.0	127.0	92.1	4.0
65	2-1/2	73.0	100	190	25.4	76	6.4	8 x 22.2	149.2	104.8	5.0
80	3	88.9	117	210	28.4	79	6.4	8 x 22.2	168.3	127.0	7.0
100	4	114.3	146	254	31.8	86	6.4	8 x 22.2	200.0	157.2	11.0
125	5	141.3	178	279	35.0	98	6.4	8 x 22.2	235.0	185.7	14.0
150	6	168.3	206	318	36.6	98	6.4	12 x 22.2	269.9	215.9	19.0
200	8	219.1	260	381	41.1	111	6.4	12 x 25.4	330.2	269.9	30.0
250	10	273.0	320	444	47.8	117	6.4	16 x 28.5	387.4	323.8	41.0
300	12	323.9	375	521	50.8	130	6.4	16 x 31.8	450.8	381.0	62.0
350	14	355.6	425	584	53.8	143	6.4	20 x 31.8	514.4	412.8	84.0
400	16	406.4	483	648	57.2	146	6.4	20 x 35.0	571.5	469.9	111.0
450	18	457.0	533	711	60.5	159	6.4	24 x 35.0	628.6	533.4	138.0
500	20	508.0	587	775	63.5	162	6.4	24 x 35.0	685.8	584.2	171.0
600	24	610.0	701	914	69.9	168	6.4	24 x 41.1	812.8	692.2	247.0

ISO PN 50 - Série 300 lbs - ASME B 16.5

- acier : réf. 10300
 - inox 316 L : réf. 10300 I
- Variantes : inox 304, ...
 Standard : pour tube épaisseur sch. 80
 Autres épaisseurs de tube sur demande

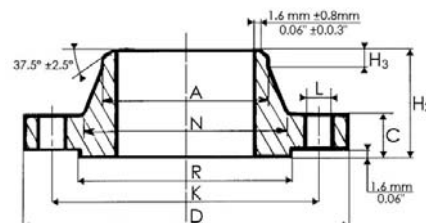

BRIDES WELDING NECK ISO PN 100 RF - WN FLANGES CLASS 600 # RF

10600

DN		Collerette		Ø ext. D	Ep. C	Hauteurs		Perçage		Portée de joint Ø R	Poids (kg)
		Ø A	Ø N			H ₂	H ₃	n x L	Ø K		
15	1/2	21.3	38	95	14.2	52	6.4	4 x 15.8	66.7	34.9	1.5
20	3/4	26.7	48	117	15.7	57	6.4	4 x 19.0	82.6	42.9	2.0
25	1	33.4	54	124	17.5	62	6.4	4 x 19.0	88.9	50.8	2.5
32	1-1/4	42.2	64	133	20.6	67	6.4	4 x 19.0	98.4	63.5	3.2
40	1-1/2	48.3	70	156	22.4	70	6.4	4 x 22.2	114.3	73.0	4.5
50	2	60.3	84	165	25.4	73	6.4	8 x 19.0	127.0	92.1	5.5
65	2-1/2	73.0	100	190	28.4	79	6.4	8 x 22.2	149.2	104.8	8.0
80	3	88.9	118	210	31.8	83	6.4	8 x 22.2	168.3	127.0	10.5
100	4	114.3	152	273	38.1	102	6.4	8 x 25.4	215.9	157.2	19.0
125	5	141.3	189	330	44.5	114	6.4	8 x 28.5	266.7	185.7	31.0
150	6	168.3	222	356	47.8	117	6.4	12 x 28.5	292.1	215.9	37.0
200	8	219.1	273	419	55.6	133	6.4	12 x 31.8	349.2	269.9	53.0
250	10	273.0	343	508	63.5	152	6.4	16 x 35.0	431.8	323.8	86.0
300	12	323.9	400	559	66.5	156	6.4	20 x 35.0	489.0	381.0	102.0
350	14	355.6	432	603	69.9	165	6.4	20 x 38.1	527.0	412.8	150.0
400	16	406.4	495	686	76.2	178	6.4	20 x 41.1	603.2	469.9	190.0
450	18	457.0	546	743	82.6	184	6.4	20 x 44.5	654.0	533.4	240.0
500	20	508.0	610	813	88.9	190	6.4	24 x 44.5	723.9	584.2	295.0
600	24	610.0	718	940	101.6	203	6.4	24 x 50.8	838.2	692.2	365.0

ISO PN 100 - Série 600 lbs - ASME B 16.5

- acier : réf. 10600
- inox 316 L : réf. 10600 I

Variantes : inox 304 L, ...
 Epaisseur de tube à préciser

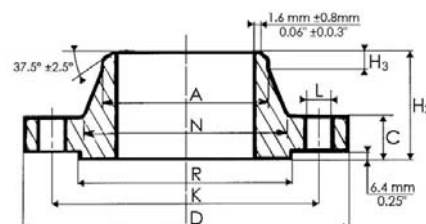

Sur demande Brides Ø ≥ 26" séries 150, 300, 600 selon ASME B16.47 (= MSS-SP 44) ou BS 3293

BRIDES SLIP-ON / BRIDES PLEINES - FACE SURELEVÉE - ASME B 16.5

SLIP-ON FLANGES / BLIND FLANGES - RAISED FACE - ASME B 16.5

BRIDES S.O. & PLEINES ISO PN 20 RF - S.O. & BL. FLANGES CLASS 150 # RF

11150 - 12150

DN	Dimensions			Perçage		Slip-on			Poids (kg)		
	D	Ø R	C	n x L	Ø K	B	N	H ₁	S.O.	Blind	
15	1/2	89	34.9	11.2	4 x 15.8	60.3	22.4	30	16	0.8	1.2
20	3/4	99	42.9	12.7	4 x 15.8	69.8	27.7	38	16	0.9	1.3
25	1	108	50.8	14.3	4 x 15.8	79.4	34.5	49	17	1.0	1.4
32	1-1/4	117	63.5	15.7	4 x 15.8	88.9	43.2	59	21	1.3	1.8
40	1-1/2	127	73.0	17.5	4 x 15.8	98.4	49.5	65	22	1.5	2.2
50	2	152	92.1	19.1	4 x 19.0	120.6	62.0	78	25	2.3	2.8
65	2-1/2	178	104.8	22.3	4 x 19.0	139.7	74.7	90	29	3.7	4.7
80	3	190	127.0	23.9	4 x 19.0	152.4	90.7	108	30	4.2	5.5
100	4	229	157.2	23.9	8 x 19.0	190.5	116.1	135	33	5.9	8.0
125	5	254	185.7	23.9	8 x 22.2	215.9	143.8	164	37	7.0	9.0
150	6	279	215.9	25.4	8 x 22.2	241.3	170.7	192	40	8.5	12.0
200	8	343	269.9	28.5	8 x 22.2	298.4	221.5	246	44	13.5	20.0
250	10	406	323.8	30.2	12 x 25.4	362.0	276.4	305	49	19.5	32.0
300	12	483	381.0	31.8	12 x 25.4	431.8	327.2	365	56	29.0	40.0
350	14	533	412.8	35.0	12 x 28.5	476.2	359.2	400	57	39.0	59.0
400	16	597	469.9	36.6	16 x 28.5	539.8	410.5	457	63	47.0	77.0
450	18	635	533.4	39.7	16 x 31.8	577.8	461.8	505	68	54.0	95.0
500	20	698	584.2	42.9	20 x 31.8	635.0	513.1	559	73	70.0	123.0
600	24	813	692.2	47.7	20 x 35.0	749.3	616.0	664	83	95.0	186.0



ISO PN 20 - Série 150 lbs - ASME B 16.5

- Bride S.O. acier : réf. **11150**
- Bride S.O. inox 316 L : réf. **11150 I**

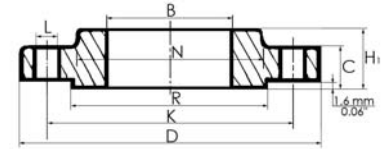

- Bride pleine acier : réf. **12150**
- Bride pleine inox 316 L : réf. **12150 I**

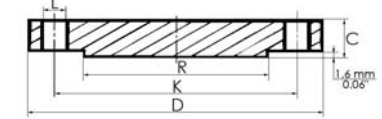

BRIDES S.O. & PLEINES ISO PN 50 RF - S.O. & BL. FLANGES CLASS 300 # RF

11300 - 12300

DN	Dimensions			Perçage		Slip-on			Poids (kg)		
	D	Ø R	C	n x L	Ø K	B	N	H ₁	S.O.	Blind	
15	1/2	95	34.9	14.2	4 x 15.8	66.7	22.4	38	22	1.2	1.5
20	3/4	117	42.9	15.7	4 x 19.0	82.6	27.7	48	25	1.3	1.6
25	1	124	50.8	17.5	4 x 19.0	88.9	34.5	54	27	1.4	2.0
32	1-1/4	133	63.5	19.0	4 x 19.0	98.4	43.2	63	27	1.8	2.5
40	1-1/2	156	73.0	20.6	4 x 22.2	114.3	49.5	70	30	2.5	3.0
50	2	165	92.1	22.4	8 x 19.0	127.0	62.0	84	33	3.0	3.5
65	2-1/2	190	104.8	25.4	8 x 22.2	149.2	74.7	100	38	4.5	5.5
80	3	210	127.0	28.4	8 x 22.2	168.3	90.7	117	43	6.0	7.0
100	4	254	157.2	31.8	8 x 22.2	200.0	116.1	146	48	10.1	12.0
125	5	279	185.7	35.0	8 x 22.2	235.0	143.8	178	51	12.5	15.8
150	6	318	215.9	36.6	12 x 22.2	269.9	170.7	206	52	17.5	23.0
200	8	381	269.9	41.1	12 x 25.4	330.2	221.5	260	62	26.0	37.0
250	10	444	323.8	47.8	16 x 28.5	387.4	276.4	320	66	38.0	58.0
300	12	521	381.0	50.8	16 x 31.8	450.8	327.2	375	73	52.0	83.0
350	14	584	412.8	53.8	20 x 31.8	514.4	359.2	425	76	74.0	107.0
400	16	648	469.9	57.2	20 x 35.0	571.5	410.5	483	83	100.0	139.0
450	18	711	533.4	60.5	24 x 35.0	628.6	461.8	533	89	127.0	177.0
500	20	775	584.2	63.5	24 x 35.0	685.8	513.1	587	95	147.0	223.0
600	24	914	692.2	69.9	24 x 41.1	812.8	616.0	701	106	208.0	342.0



ISO PN 50 - Série 300 lbs - ASME B 16.5

- Bride S.O. acier : réf. **11300**
- Bride S.O. inox 316 L : réf. **11300 I**

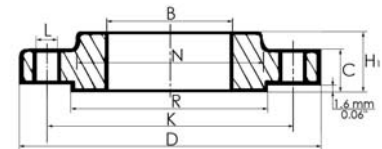

- Bride pleine acier : réf. **12300**
- Bride pleine inox 316 L : réf. **12300 I**

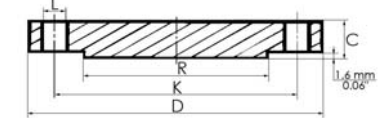

BRIDES S.O. & PLEINES ISO PN 100 RF - S.O. & BL. FLANGES CLASS 600 # RF

11600 - 12600

DN	Dimensions			Perçage		Slip-on			Poids (kg)		
	D	Ø R	C	n x L	Ø K	B	N	H ₁	S.O.	Blind	
15	1/2	95	34.9	14.2	4 x 15.8	66.7	22.4	38	22	1.3	1.4
20	3/4	117	42.9	15.7	4 x 19.0	82.6	27.7	48	25	1.4	1.6
25	1	124	50.8	17.5	4 x 19.0	88.9	34.5	54	27	1.8	2.1
32	1-1/4	133	63.5	20.6	4 x 19.0	98.4	43.2	64	29	2.1	2.6
40	1-1/2	156	73.0	22.4	4 x 22.2	114.3	49.5	70	32	3.1	3.3
50	2	165	92.1	25.4	8 x 19.0	127.0	62.0	84	37	4.0	4.4
65	2-1/2	190	104.8	28.4	8 x 22.2	149.2	74.7	100	41	5.4	6.0
80	3	210	127.0	31.8	8 x 22.2	168.3	90.7	118	46	7.0	7.4
100	4	273	157.2	38.1	8 x 25.4	215.9	116.1	152	54	16.0	17.0
125	5	330	185.7	44.5	8 x 28.5	266.7	143.8	189	60	25.0	27.0
150	6	356	215.9	47.8	12 x 28.5	292.1	170.7	222	67	30.0	32.0
200	8	419	269.9	55.6	12 x 31.8	349.2	221.5	273	76	43.0	46.0
250	10	508	323.8	63.5	16 x 35.0	431.8	276.4	343	86	70.0	74.0
300	12	559	381.0	66.5	20 x 35.0	489.0	327.2	400	92	86.0	90.0
350	14	603	412.8	69.9	20 x 38.1	527.0	359.2	432	94	100.0	108.0
400	16	686	469.9	76.2	20 x 41.1	603.2	410.5	495	106	142.0	150.0
450	18	743	533.4	82.6	20 x 44.5	654.0	461.8	546	117	175.0	188.0
500	20	813	584.2	88.9	24 x 44.5	723.9	513.1	610	127	221.0	230.0
600	24	940	692.2	101.6	24 x 50.8	838.2	616.0	718	140	315.0	325.0



ISO PN 100 - Série 600 lbs - ASME B 16.5

- Bride S.O. acier : réf. **11600**
- Bride S.O. inox 316 L : réf. **11600 I**

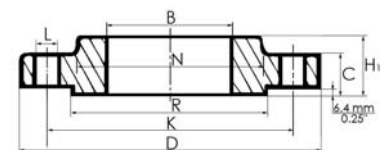

- Bride pleine acier : réf. **12600**
- Bride pleine inox 316 L : réf. **12600 I**

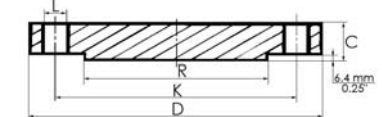

BRIDES TOURNANTES ACIER - ASME B 16.5
CARBON STEEL LAP JOINT FLANGES - ASME B 16.5

BRIDE TOURNANTE ISO PN 20 - LJ FLANGE CLASS 150 #

10150 LJ

DN	Alésage B ₂	Collerette Ø N	Ø ext. D	Ep. C	H ₄	Perçage		R	Poids (kg)	
						n x L	Ø K			
15	1/2	22.9	30	89	11.2	16	4 x 15.8	60.3	3	0.8
20	3/4	28.2	38	99	12.7	16	4 x 15.8	69.8	3	0.9
25	1	35.0	49	108	14.3	17	4 x 15.8	79.4	3	1.0
32	1-1/4	43.7	59	117	15.7	21	4 x 15.8	88.9	5	1.3
40	1-1/2	50.0	65	127	17.5	22	4 x 15.8	98.4	6	1.5
50	2	62.5	78	152	19.1	25	4 x 19.0	120.6	8	2.3
65	2-1/2	75.4	90	178	22.3	29	4 x 19.0	139.7	8	3.7
80	3	91.4	108	190	23.9	30	4 x 19.0	152.4	10	4.2
100	4	116.8	135	229	23.9	33	8 x 19.0	190.5	11	5.9
125	5	144.5	164	254	23.9	37	8 x 22.2	215.9	11	7.0
150	6	171.4	192	279	25.4	40	8 x 22.2	241.3	13	8.5
200	8	222.2	246	343	28.5	44	8 x 22.2	298.4	13	13.5
250	10	277.4	305	406	30.2	49	12 x 25.4	362.0	13	19.5
300	12	328.2	365	483	31.8	56	12 x 25.4	431.8	13	29.0
350	14	360.2	400	533	35.0	79	12 x 28.5	476.2	13	45.0
400	16	411.2	457	597	36.6	87	16 x 28.5	539.8	13	58.0
450	18	462.3	505	635	39.7	97	16 x 31.8	577.8	13	66.0
500	20	514.4	559	698	42.9	103	20 x 31.8	635.0	13	84.0
600	24	616.0	664	813	47.7	111	20 x 35.0	749.3	13	118.0



ISO PN 20 - Série 150 lbs - ASME B 16.5
 Acier carbone
 Variantes : inox 304 L, 316 L, ...

ISO PN 20 - Class 150 lbs - ASME B 16.5
 Carbon steel construction
 Alternates : AISI 304 L, 316 L

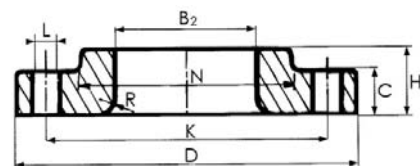

BRIDE TOURNANTE ISO PN 50 - LJ FLANGE CLASS 300 #

10300 LJ

DN	Alésage B ₂	Collerette Ø N	Ø ext. D	Ep. C	H ₄	Perçage		R	Poids (kg)	
						n x L	Ø K			
15	1/2	22.9	38	95	14.2	22	4 x 15.8	66.7	3	1.2
20	3/4	28.2	48	117	15.7	25	4 x 19.0	82.6	3	1.3
25	1	35.0	54	124	17.5	27	4 x 19.0	88.9	3	1.4
32	1-1/4	43.7	63	133	19.0	27	4 x 19.0	98.4	5	1.8
40	1-1/2	50.0	70	156	20.6	30	4 x 22.2	114.3	6	2.5
50	2	62.5	84	165	22.4	33	8 x 19.0	127.0	8	3.0
65	2-1/2	75.4	100	190	25.4	38	8 x 22.2	149.2	8	4.5
80	3	91.4	117	210	28.4	43	8 x 22.2	168.3	10	6.0
100	4	116.8	146	254	31.8	48	8 x 22.2	200.0	11	10.1
125	5	144.5	178	279	35.0	51	8 x 22.2	235.0	11	12.5
150	6	171.4	206	318	36.6	52	12 x 22.2	269.9	13	17.5
200	8	222.2	260	381	41.1	62	12 x 25.4	330.2	13	26.0
250	10	277.4	320	444	47.8	95	16 x 28.5	387.4	13	41.0
300	12	328.2	375	521	50.8	102	16 x 31.8	450.8	13	63.0
350	14	360.2	425	584	53.8	111	20 x 31.8	514.4	13	86.0
400	16	411.2	483	648	57.2	121	20 x 35.0	571.5	13	109.0
450	18	462.3	533	711	60.5	130	24 x 35.0	628.6	13	138.0
500	20	514.4	587	775	63.5	140	24 x 35.0	685.8	13	170.0
600	24	616.0	701	914	69.9	152	24 x 41.1	812.8	13	241.0

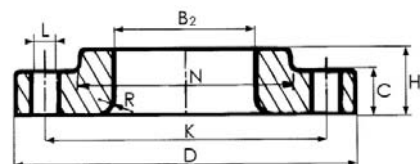

ISO PN 50 - Série 300 lbs - ASME B 16.5
 Acier carbone
 Variantes : inox 304 L, 316 L, ...

ISO PN 50 - Class 300 lbs - ASME B 16.5
 Carbon steel construction
 Alternates : AISI 304 L, 316 L

BRIDE TOURNANTE ISO PN 100 - LJ FLANGE CLASS 600 #

10600 LJ

DN	Alésage B ₂	Collerette Ø N	Ø ext. D	Ep. C	H ₄	Perçage		R	Poids (kg)	
						n x L	Ø K			
15	1/2	22.9	38	95	14.2	22	4 x 15.8	66.7	3	1.3
20	3/4	29.2	48	117	15.7	25	4 x 19.0	82.6	3	1.4
25	1	35.0	54	124	17.5	27	4 x 19.0	88.9	3	1.8
32	1-1/4	43.7	64	133	20.6	29	4 x 19.0	98.4	5	2.1
40	1-1/2	50.0	70	156	22.4	32	4 x 22.2	114.3	6	3.1
50	2	62.5	84	165	25.4	37	8 x 19.0	127.0	8	4.0
65	2-1/2	75.4	100	190	28.4	41	8 x 22.2	149.2	8	5.4
80	3	91.4	118	210	31.8	46	8 x 22.2	168.3	10	7.0
100	4	116.8	152	273	38.1	54	8 x 25.4	215.9	11	16.0
125	5	144.5	189	330	44.5	60	8 x 28.5	266.7	11	25.0
150	6	171.4	222	356	47.8	67	12 x 28.5	292.1	13	30.0
200	8	222.2	273	419	55.6	76	12 x 31.8	349.2	13	43.0
250	10	277.4	343	508	63.5	111	16 x 35.0	431.8	13	89.0
300	12	328.2	400	559	66.5	117	20 x 35.0	489.0	13	109.0
350	14	360.2	432	603	69.9	127	20 x 38.1	527.0	13	132.0
400	16	411.2	495	686	76.2	140	20 x 41.1	603.2	13	182.0
450	18	462.3	546	743	82.6	152	20 x 44.5	654.0	13	213.0
500	20	514.4	610	813	88.9	165	24 x 44.5	723.9	13	274.0
600	24	616.0	718	940	101.6	184	24 x 50.8	838.2	13	393.0

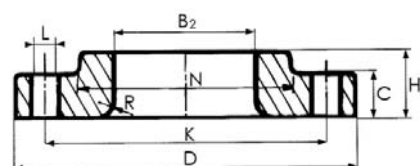

ISO PN 100 - Série 600 lbs - ASME B 16.5
 Acier carbone
 Variantes : inox 304 L, 316 L, ...

ISO PN 100 - Class 600 lbs - ASME B 16.5
 Carbon steel construction
 Alternates : AISI 304 L, 316 L

BRIDES TARAUEES / BRIDES A EMBOITER - ASME B 16.5
THREADED FLANGES / HUBBED SOCKET WELDING FLANGES - ASME B 16.5



Construction suivant ASME B 16.5

Execution according to ASME B 16.5

Matériau : acier carbone

Carbon steel construction

Variantes : inox 304 L, 316 L, ...

Alternates : AISI 304 L, 316 L, ...

BRIDES TARAUEES OU A EMBOITER ISO PN 20 RF
THREADED OR SW FLANGES CLASS 150 # RF

10150 T - 10150 SW

DN	Ø N	Ø ext. D	Ep. C	H ₁	Perçage		Ø R	SW		Poids (kg)	
					n x L	Ø K		B ₁	U		
15	1/2	30	89	11.2	16	4 x 15.8	60.3	34.9	22.4	10	0.8
20	3/4	38	99	12.7	16	4 x 15.8	69.8	42.9	27.7	11	0.9
25	1	49	108	14.3	17	4 x 15.8	79.4	50.8	34.5	13	1.0
32	1-1/4	59	117	15.7	21	4 x 15.8	88.9	63.5	43.2	14	1.3
40	1-1/2	65	127	17.5	22	4 x 15.8	98.4	73.0	49.5	16	1.5
50	2	78	152	19.1	25	4 x 19.0	120.6	92.1	62.0	17	2.3
65	2-1/2	90	178	22.3	29	4 x 19.0	139.7	104.8	74.7	19	3.7
80	3	108	190	23.9	30	4 x 19.0	152.4	127.0	90.7	21	4.2
100	4	135	229	23.9	33	8 x 19.0	190.5	157.2	-	-	5.9
125	5	164	254	23.9	37	8 x 22.2	215.9	185.7	-	-	7.0
150	6	192	279	25.4	40	8 x 22.2	241.3	215.9	-	-	8.5
200	8	246	343	28.5	44	8 x 22.2	298.4	269.9	-	-	13.5

ISO PN 20 - Série 150 lbs

Bride taraudée - Threaded flange

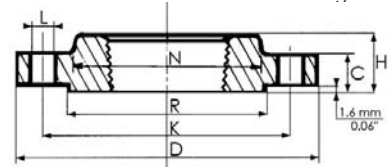

Bride à emboiter - SW flange

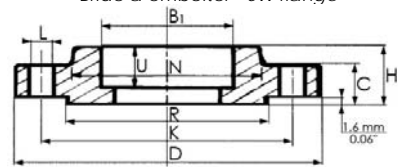

BRIDES TARAUEES OU A EMBOITER ISO PN 50 RF
THREADED OR SW FLANGES CLASS 300 # RF

10300 T - 10300 SW

DN	Ø N	Ø ext. D	Ep. C	H ₁	Perçage		Ø R	SW		Poids (kg)	
					n x L	Ø K		B ₁	U		
15	1/2	38	95	14.2	22	4 x 15.8	66.7	34.9	22.4	10	1.2
20	3/4	48	117	15.7	25	4 x 19.0	82.6	42.9	27.7	11	1.3
25	1	54	124	17.5	27	4 x 19.0	88.9	50.8	34.5	13	1.4
32	1-1/4	63	133	19.0	27	4 x 19.0	98.4	63.5	43.2	14	1.9
40	1-1/2	70	156	20.6	30	4 x 22.2	114.3	73.0	49.5	16	2.8
50	2	84	165	22.4	33	8 x 19.0	127.0	92.1	62.0	17	3.3
65	2-1/2	100	190	25.4	38	8 x 22.2	149.2	104.8	74.7	19	4.6
80	3	117	210	28.4	43	8 x 22.2	168.3	127.0	90.7	21	6.3
100	4	146	254	31.8	48	8 x 22.2	200.0	157.2	-	-	10.2
125	5	178	279	35.0	51	8 x 22.2	235.0	185.7	-	-	12.9
150	6	206	318	36.6	52	12 x 22.2	269.9	215.9	-	-	18.0
200	8	260	381	41.1	62	12 x 25.4	330.2	269.9	-	-	26.0

ISO PN 50 - Série 300 lbs

Bride taraudée - Threaded flange

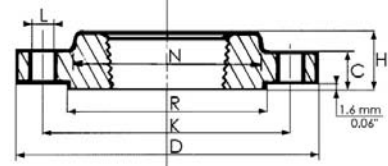

Bride à emboiter - SW flange

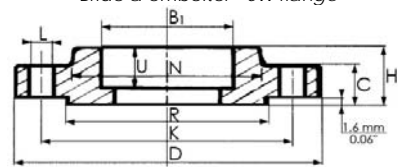

BRIDES TARAUEES OU A EMBOITER ISO PN 100 RF
THREADED OR SW FLANGES CLASS 600 # RF

10600 T - 10600 SW

DN	Ø N	Ø ext. D	Ep. C	H ₁	Perçage		Ø R	SW		Poids (kg)	
					n x L	Ø K		B ₁	U		
15	1/2	38	95	14.2	22	4 x 15.8	66.7	34.9	22.4	10	1.4
20	3/4	48	117	15.7	25	4 x 19.0	82.6	42.9	27.7	11	1.6
25	1	54	124	17.5	27	4 x 19.0	88.9	50.8	34.5	13	2.1
32	1-1/4	64	133	20.6	29	4 x 19.0	98.4	63.5	43.2	14	2.6
40	1-1/2	70	156	22.4	32	4 x 22.2	114.3	73.0	49.5	16	3.3
50	2	84	165	25.4	37	8 x 19.0	127.0	92.1	62.0	17	4.4
65	2-1/2	100	190	28.4	41	8 x 22.2	149.2	104.8	74.7	19	6.0
80	3	118	210	31.8	46	8 x 22.2	168.3	127.0	90.7	21	7.4
100	4	152	273	38.1	54	8 x 25.4	215.9	157.2	-	-	17.0
125	5	189	330	44.5	60	8 x 28.5	266.7	185.7	-	-	27.0
150	6	222	356	47.8	67	12 x 28.5	292.1	215.9	-	-	32.0
200	8	273	419	55.6	76	12 x 31.8	349.2	269.9	-	-	46.0

ISO PN 100 - Série 600 lbs

Bride taraudée - Threaded flange

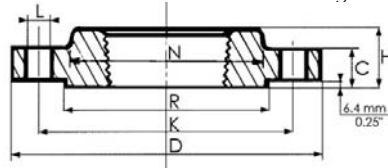

Bride à emboiter - SW flange

